

SP30~60HCPS Series Microgrid Energy Storage converter Product Specification

version: V1.5

date: August 02(th), 2026

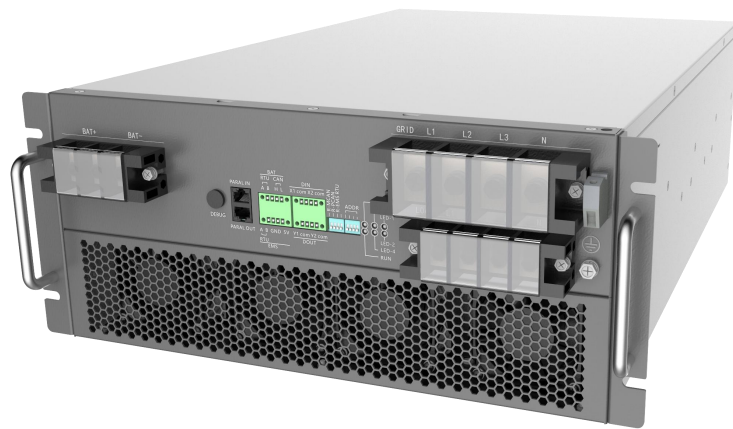

catalogue

1. Product introduction	1
1.1 main topology	1
1.2 product features	1
2. Product model and size	2
2.1. Product model	2
2.2. naming rule	2
2.3. Product appearance and size	3
3. Specification parameter	5
3.1. parameter	5
3.2. Power derating curve (battery voltage)	6
3.3. Power derating curve (Grid voltage)	8
3.4. Temperature derating curve	9
3.5. Safety protection	9
4. Port definition	10
5. Heat dissipation requirements	15
5.1. Air inlet and outlet mode	15
5.2. Heat dissipation requirements	15
6. Application scenarios	17
6.1. Small industrial and commercial energy storage	17
6.2. Solution of off-grid microgrid	18
6.3. Three-phase imbalance and low voltage control	18
6.4. Energy storage+emergency standby power	20
6.5. Multi-machine parallel scheme	20
7. External EMS scheduling function (select to breed)	22
7.1. Introduction of microgrid EMS	22
7.2. EMS function	22
7.3. EMS working model	23
7.4. Other EMS parameter information	23

1. Product introduction

An efficient and highly reliable energy storage converter is mainly developed for small and medium-sized energy storage microgrids, which includes a parallel and off-grid switching device, supports multiple parallel operation, supports hybrid operation of oil and gas engines, and supports fast parallel and off-grid switching. It is suitable for small-scale industry and commerce, small-scale island microgrid, farm, villa, battery cascade utilization and other scenarios to meet the needs of different users.

1.1 main topology

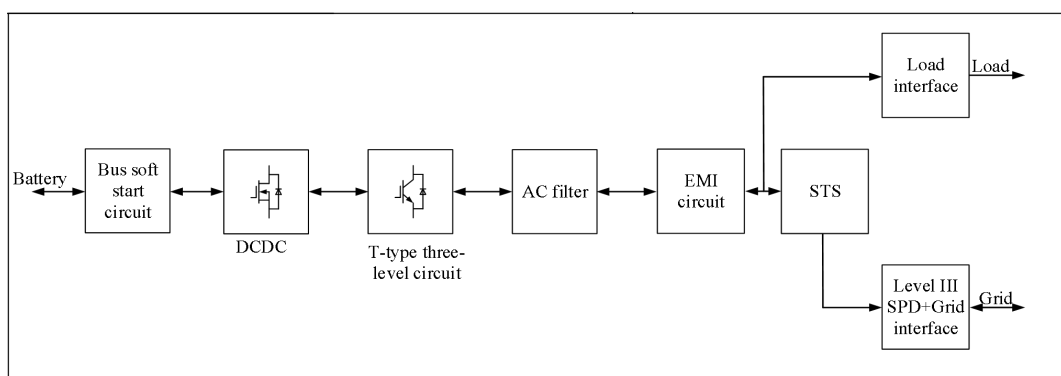

Picture 1

1.2 product features

(1) High efficiency and high reliability:

- **low power consumption:** Standby power consumption is low $\leq 15W$, and no-load running loss is less than 160W;
- **high efficiency:** maximum conversion efficiency 98.2%;
- **High protection:** The core control part has the protection level of IP5X, which can work stably in harsh environment, such as dust and high salt fog;
- **Air duct isolation design:** The design of isolated air duct improves the safety and reliability of products;
- **High overload capacity:** It has 150% instantaneous overload capacity, which enhances the adaptability and durability of the system;
- **Seamless switching function:** Support seamless switching from grid to grid, ensuring the

continuity and stability of power supply.

(2) function:

- **Oil-engine hybrid mode:** It supports the mixed operation of oil engine, provides flexible energy combination mode, and improves energy utilization efficiency;
- **Three-phase independent grid-connected control technology:** It realizes three-phase independent control, optimizes power distribution and improves the flexibility and efficiency of the system.
- **seamless handover:** Seamless switching from parallel to off-grid (less than 10ms) ;
- **Power grid adaptability:** Perfect high and low voltage crossing function, island protection, black start and other functions;
- **Parallel machine function:** The AC side supports 15 parallel grid-connected or off-grid operation;
- **Flexible application scenarios:** suitable for small-scale industry and commerce, small-scale island microgrid, farms, villas and other scenarios to meet the specific needs of different users.

(3) Convenience:

- **Communication and monitoring:** Support a variety of communication protocols, support mainstream BMS protocols, and facilitate remote monitoring and management;
- **High maintainability:** Front wiring and maintenance;
- **Fault protection:** Perfect fault protection and fault recording function;
- **Wide voltage range:** It is suitable for voltage input of various battery configurations, with strong adaptability, and can meet the energy demand of different capacity requirements. The battery has better adaptability and higher cost performance, as low as 200V, for example 30kW/20-70kWh(100AH)、30kW/(60-215)kWh(280AH)。

2. Product model and size

2.1. Product model

SP60HCPS、SP50HCPS、SP40HCPS、SP30HCPS

2.2. naming rule

This document is applicable to the model description of SP**HC** series products.

serial number	code	meaning
1	name of the company	SP: Sino Soar
2	Ac rated power	60: Rated AC output power 60kW 50: Rated AC output power 50kW 40: Rated AC output power 40kW 30: Rated AC output power 30kW
3	Dc voltage level	H: The DC side input voltage is at 200~1000V
4	Assembly mode	C: Insert frame
5	Module classification	G2: Hybrid energy storage inverter PS: Energy storage converter DC: Dc converter PV: DC MPPT IV: Inverter

2.3. Product appearance and size

(1) Product appearance





Picture 2

(2) Product size

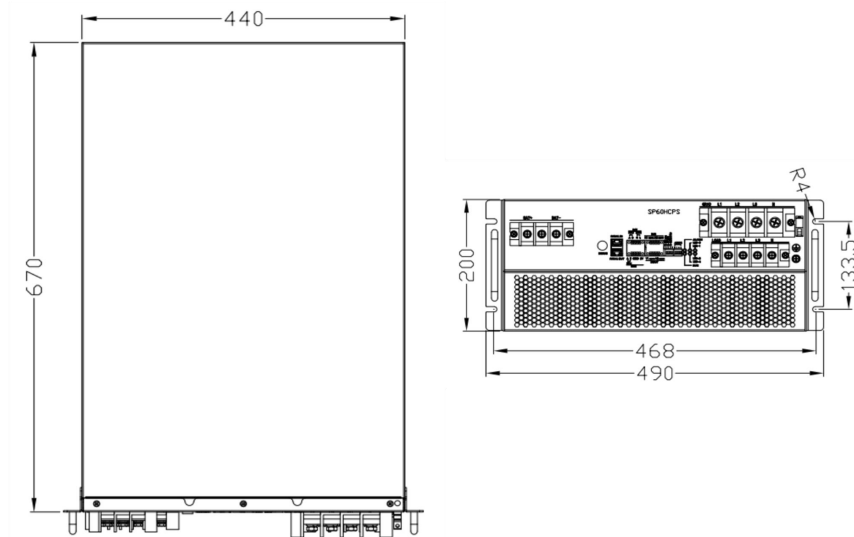

Picture 3

3. Specification parameter

3.1. parameter

parameter	SP60HCPS	SP50HCPS	SP40HCPS	SP30HCPS
Battery parameters				
Maximum battery voltage	850V			
Minimum battery voltage	200V			
Supported battery types	Lithium iron phosphate battery, ternary battery, lead-acid battery, etc.			
Rated battery voltage range	420V-850V	350V-850V	270V-850V	210V-850V
Maximum battery current	150A			
Ac side (parallel in)				
Rated power	60kVA	50kVA	40kVA	30kVA
Rated current	87A	72.5A	58A	43.5A
Maximum bypass current	174A	145A	116A	87A
Rated grid voltage	400V/230V			
Grid voltage range	-20%~15%			
Power grid frequency range	50Hz/47Hz~52Hz(60Hz/57Hz~62Hz)			
Current harmonics	<3% (more than 30% load)			
Power factor	-1~1			
AC side (off-grid)				
Output rating	60kVA	50kVA	40kVA	30kVA
Maximum output power	66kVA	55kVA	44kVA	33kVA
Rated output current	87A	72.5A	58A	43.5A
Maximum output current	95.7A	79.8A	63.8A	47.9A
Rated voltage	400V/230V			
Output voltage harmonics	<3%(Resistive load)			
Degree of unbalancedness	100%			
Frequency range	50/60Hz			

Output overload (current) I_c :	$I_c * 1.1 < I_{load} \leq I_c * 1.25$	100s
Rated output current:	$I_c * 1.25 < I_{load}$	300ms
system parameter		
Communication port	EMS: RS485 Battery: CAN or RS485	
DIDO	DI: 2 channels; DO: 2 channels	
Maximum efficiency	97.8%	
Installation mode	Insert frame	
Wastage	standby time < 15W, no-load power < 160W	
Weight	≤ 50kg	
Size	W*L*H: 440*670*200mm	
Protect	IP20	
Temperature range	-30--60 °C (45 °C derate)	
Humidity range	5-95%	
Cooling mode	Intelligent forced air cooling	
Altitude	4000m (2000m Use above derating)	
Authentication	CE, IEC62019, IEC62477, IEC6100, EN50549	

3.2. Power derating curve (battery voltage)

SP60HCPS Curve of battery side charging and discharging power and battery voltage

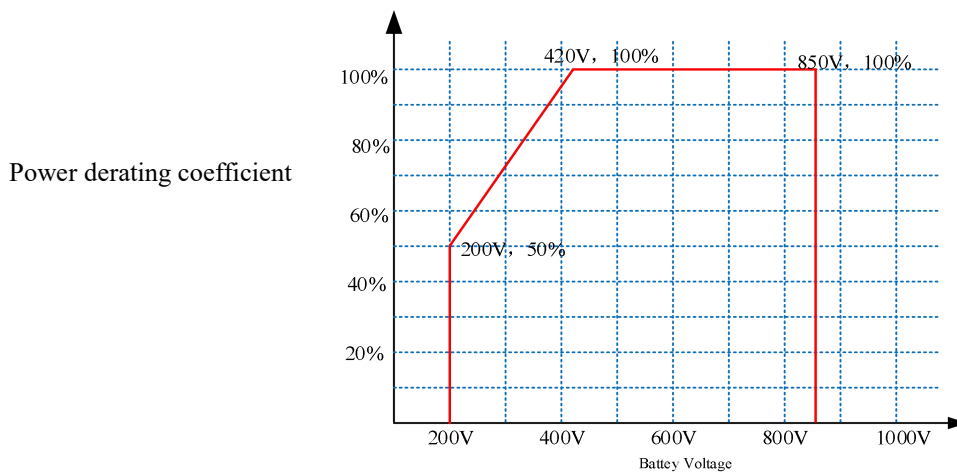

Picture 4

SP50HCPS Curve of battery side charging and discharging power and battery voltage

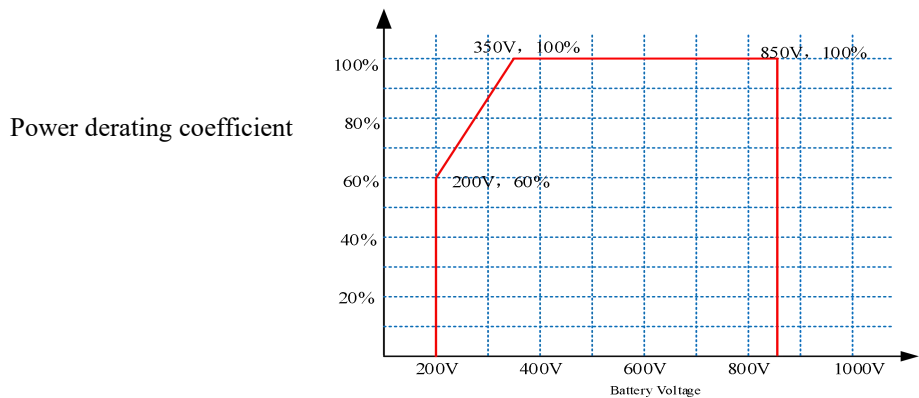

Picture 5

SP40HCPS Curve of battery side charging and discharging power and battery voltage

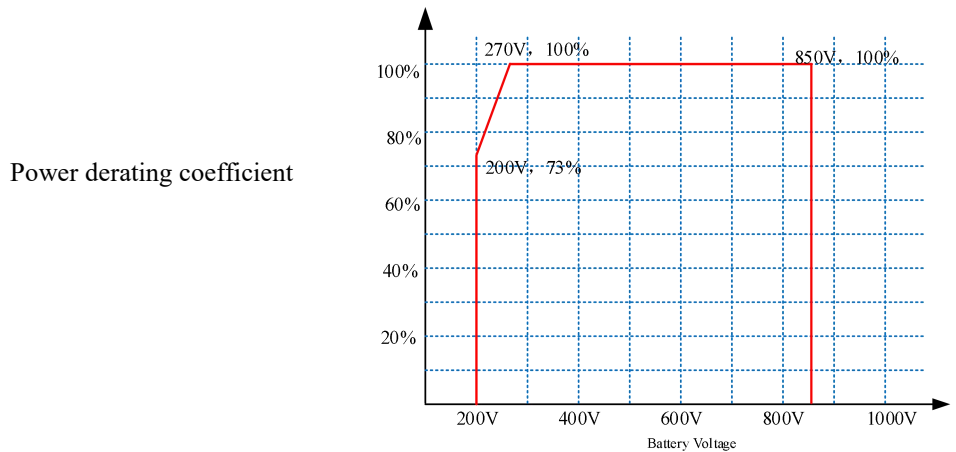

Picture 6

Curve of charging and discharging power and battery voltage at SP30HCPS battery side

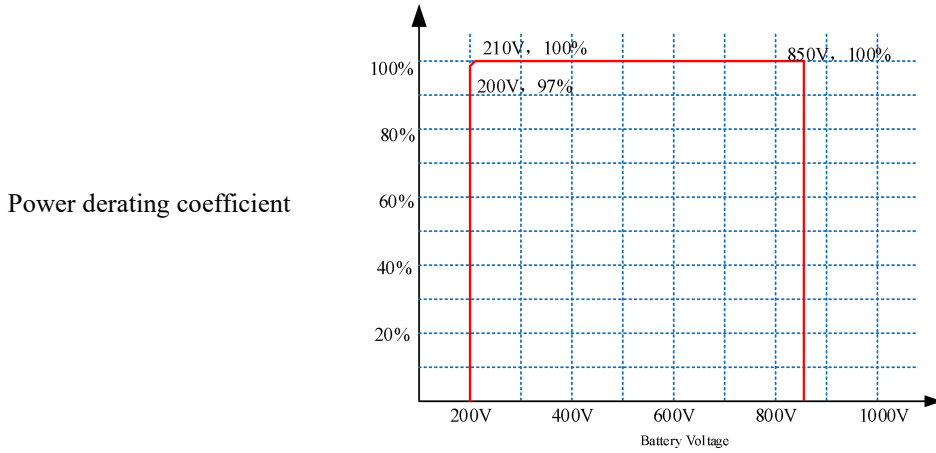

Picture 7

3.3. Power derating curve (Grid voltage)

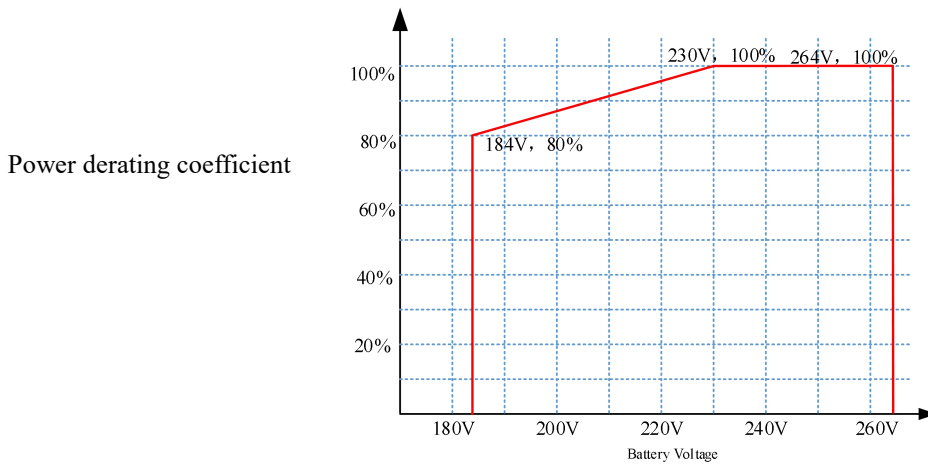

Picture 8

3.4. Temperature derating curve

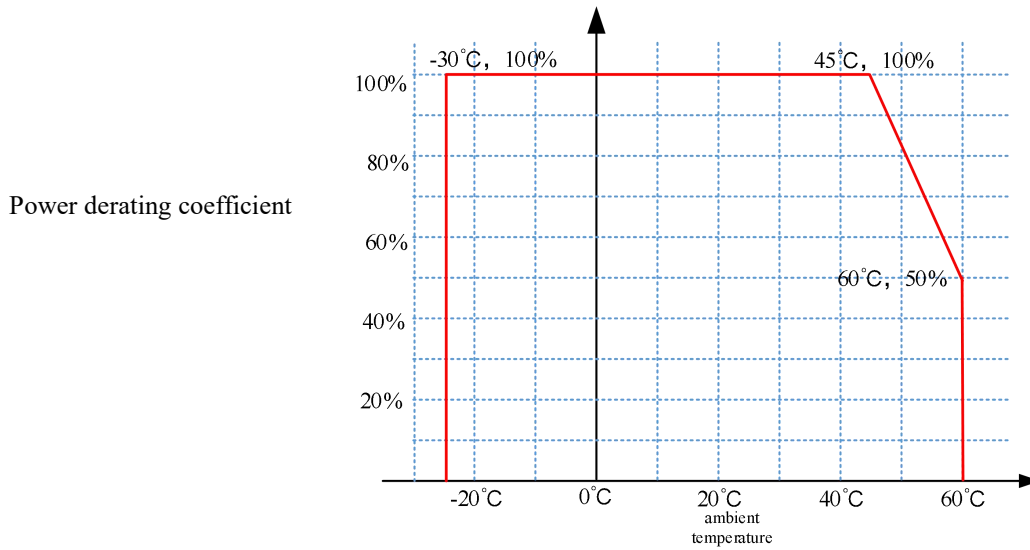

Picture 9

3.5. Safety protection

- Air duct isolation, salt spray prevention and control warehouse sealing;
- Humidity range 5%-95%;
- Anti-interference 2KV grounding, Class III lightning protection, and Class II lightning protection is required for AC side or power distribution unit during the application of PCS;
- Running vibration test, transportation test with packing material.

4. Port definition

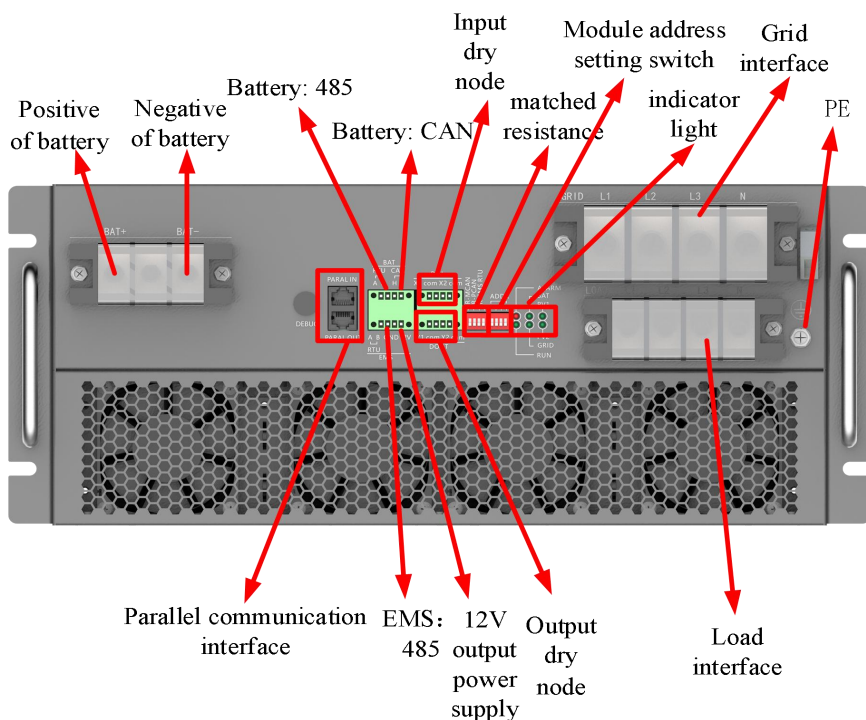

Picture 10 Port definition schematic

Power port definition:

name	function	remarks
BAT+/BAT-	Battery input terminal	OT terminal(RNB38-6), 35mm ² wire cable
LOAD (L1/L2/L3/N)	AC load terminal	OT terminal(RNB22-6S), 25mm ² wire cable
GRID (L1/L2/L3/N)	AC power network terminal	OT terminal(RNB60-8), 50mm ² wire cable
PE	ground terminal	OT terminal(RNB22-6S), 10mm ² wire cable



- The power terminals of the battery interface and the load interface are fixed with M6 screws. Please fix the power cable with the supplied screws, and the torque of the fixing screws is 5.5~6.5N.m. Too large will lead to terminal damage, and too small will lead to poor contact.
- The power terminal of the power grid is fixed with M8 screws. Please use the screws provided with it to fix the power cable, and the torque of the fixing screws is 15.5~16.5

N.m . Too large will lead to terminal damage, and too small will lead to poor contact.

- The module shall be reliably grounded during operation. Poor grounding may lead to electric shock danger and damage to the module. The torque of the fixing screw is 5 N.m.

The definition of signal terminal interface is shown in Picture 11.

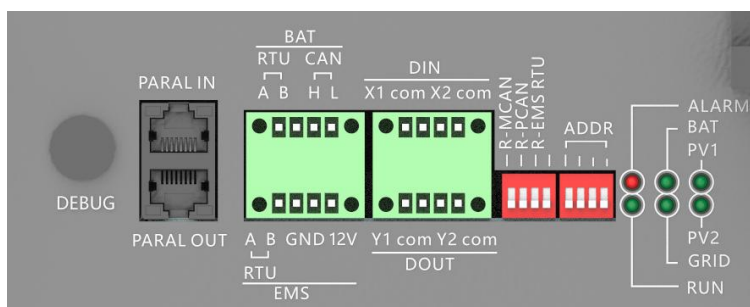

Picture 11 Definition of signal terminal interface

name	function	remarks
PARAL IN	Parallel line input	Parallel line
PARAL OUT	Parallel line output	Parallel line
BAT_RTU	Battery RS485 interface	BAT communication interface
BAT_CAN	Battery CAN interface	
RTU(A-B)	Communication interface with EMS	Upper computer or EMS or SAEMS100 (optional) coordinated control system.
12V-GND	SAEMS Power supply port	Output capacity 12V/0.5A
X1	Input dry contact	emergency stop button
X1_com	Input dry contact	
X2	Input dry contact	reserve
X2_com	Input dry contact	reserve
Y1	Output dry contact	Output capacity: the maximum voltage of the port is not higher than 24V, and the maximum current is not more than 200mA.
com		
Y2	Output dry contact	
com		
R-MCAN	Parallel communication matching resistor	ON: indicates that the communication matching resistor is connected.
R-PCAN	Parallel communication matching resistor	Module 1 and the last module need to be connected with parallel communication matching resistors (dial the code to the ON position), that is, parallel communication matching resistors are needed at the beginning and end, and others are not needed.
R-EMS RTU	EMS RTU Communication matching resistance	
ADDR	Module address dialing	ON: 1, otherwise 0. The address of the module is expressed in binary, with the high position on the left and the low position on the right, that is, the No.1 module is expressed as 0001; Module 3 is indicated as 0011.

DEBUG	Debugging interface	For internal debugging only.
ALARM	trouble lamp	The converter is always on when there is a fault, and always off when there is no fault.
RUN	status indicator lamp	The converter is always on during normal operation, and flashes once per second during trouble-free standby, and the converter often goes out when it fails.
BAT	Battery status indicator lamp	The function of the battery terminal circuit is always on when it is running, it flashes once per second when the battery is normal, and it is always off when the battery is abnormal.
GRID	Power grid status indicator lamp	Grid-connected operation is always on, and the power grid flashes once per second when there is no abnormality, and the power grid is always off when there is abnormality.
PV1	reserve	
PV2	reserve	

The internal schematic diagram of the output trunk node is shown in Picture 12.:

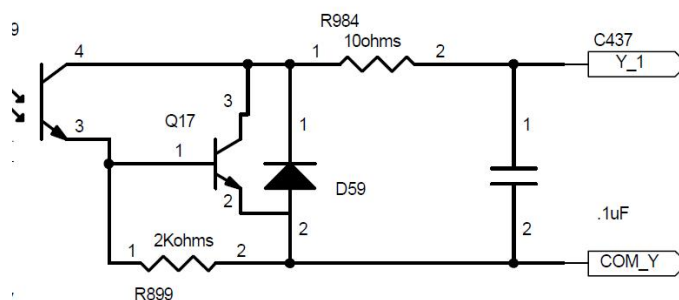

Picture 12 Internal principle of output trunk node

The maximum port voltage is not higher than 24V, Maximum current does not exceed 200mA。

The internal schematic diagram of the input stem node is shown in Picture 13.:

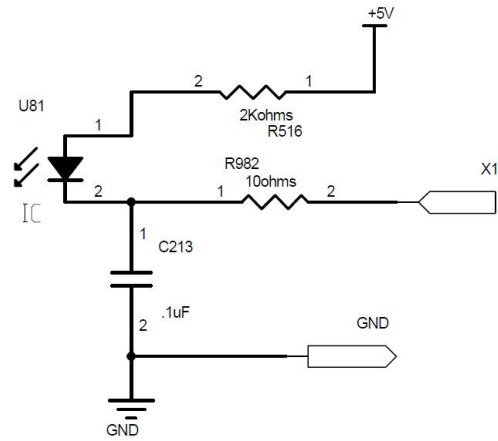

Picture 13 Input internal schematic diagram of dry node

The input trunk node has a built-in power supply, so it only needs to provide a switch for short circuit, and the sum of the short circuit impedance of the switch and the line impedance should be less than 0.1Ω .

5. Heat dissipation requirements

5.1. Air inlet and outlet mode

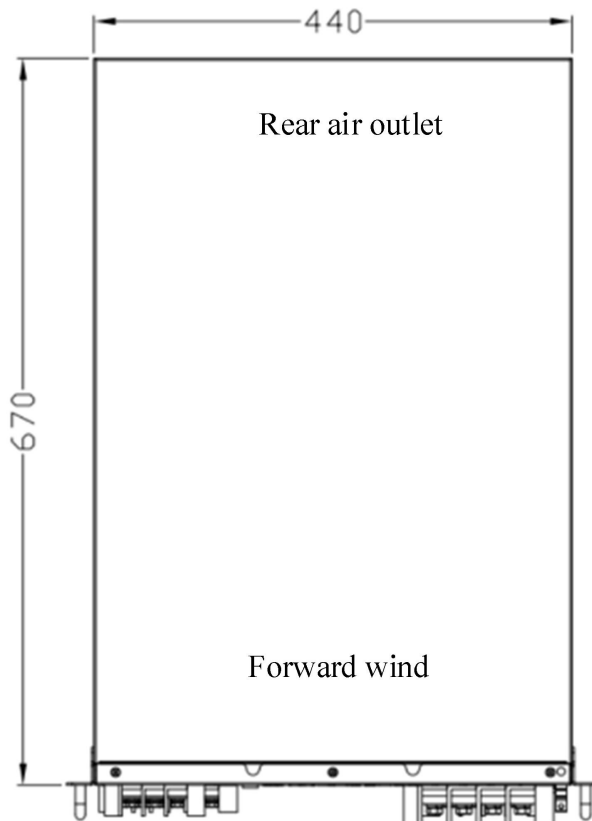

Picture 14

5.2. Heat dissipation requirements

The cooling mode of converter module is forced air cooling, with air inlet on the front panel and air outlet on the back panel. The rated air inlet of converter module is 500CFM(14.1m³/min). When installed in an integrated system, the air inlet of the cabinet should face the air inlet of the front panel of the module, and the distance between the air inlet of converter module and the cabinet should be greater than 110mm; Corresponding air ducts and air outlets should also be added to the cabinet, which should be opposite to the module air outlet and the cabinet air outlet, and the distance between the converter module air outlet and the cabinet body should be greater than 110mm, so as to directly send the hot air outside the cabinet and avoid the backflow of the hot air in the cabinet. If there is no relevant air outlet duct, an exhaust fan should be added at the air outlet of the cabinet, and the air volume of the fan should be 2 times of the air intake requirement of the module. Considering that dust-

proof cotton needs to be added to the air inlet, the air inlet area of the cabinet should be three times larger than that of the converter module. It is recommended to use polyurethane reticulated foam cotton with 40PPI density for dust-proof cotton, and the flame retardant grade should meet 94V0. The air outlet area of the cabinet should be twice that of the converter module, and it is recommended to use 10 mesh insect-proof steel mesh at the air outlet. Refer to fig. 14 for air intake.

6. Application scenarios

- **Small industry and commerce:** Suitable for small factories, commercial buildings, office buildings, etc., it is used to optimize energy consumption, realize peak-valley electricity price management, reduce electricity expenditure, and provide emergency power reserve function to ensure the normal operation of key equipment when the power grid is unstable;
- **Farms and agricultural facilities:** In the agricultural field, the inverter can be combined with diesel generator and energy storage system to provide power for irrigation, greenhouse control, automation equipment, etc., and at the same time support the hybrid mode of oil and machine to ensure that it can still maintain operation when energy is insufficient;
- **Villa and residence:** Provide energy solutions for high-end residential buildings, realize the combination of diesel generators and energy storage, improve the energy self-sufficiency rate, and provide household emergency power supply to ensure that household electricity consumption will not be affected when the power grid fails;
- **Temporary electricity consumption and construction site:** In construction sites, outdoor activities, temporary facilities and other scenes, it can be used as a mobile power supply to provide necessary power support, and at the same time support oil-engine mixing to ensure the continuity of power supply;
- **Remote areas and emergency rescue:** In remote areas or emergency rescue scenes, it has light weight, high integration, rapid deployment, stable power supply and support for the operation of key facilities such as communication equipment and medical equipment;
- **Battery cascade utilization:** Participate in national or regional energy optimization projects, such as the demonstration project of diesel storage island, and demonstrate the performance and benefits in practical application.

6.1. Small industrial and commercial energy storage

Main application scenarios: home, villa, supermarket, farm, field construction and other scenarios.

Main functions: emergency power supply, etc.

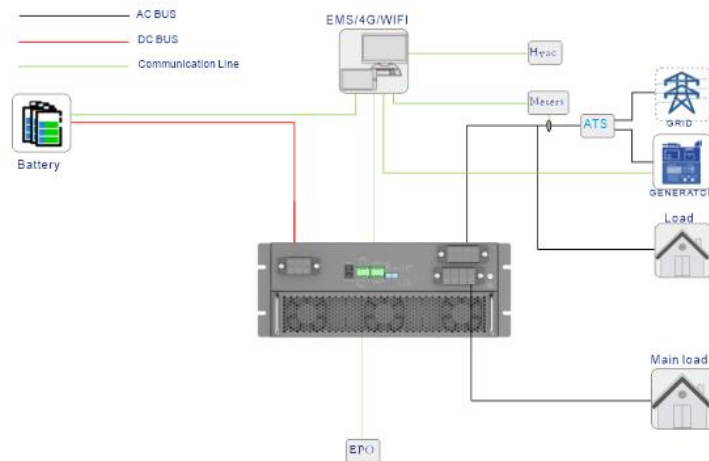

Picture 15

6.2. Solution of off-grid microgrid

Main application scenarios: power unstable areas, villas, farms, islands, oil production, and other areas without electricity.

Main functions: emergency power supply, oil engine management, etc.

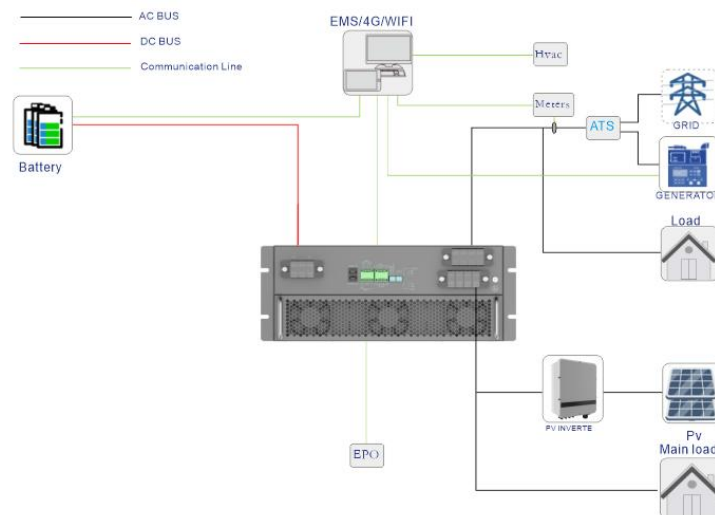

Picture 16

6.3. Three-phase imbalance and low voltage control

Main application scenarios: high-voltage, low-voltage and unbalanced terminal grid voltage caused by new energy access or load fluctuation and line impedance.

Major function: three-phase independent grid-connected independent control to achieve energy balance and maximum compensation 150%。

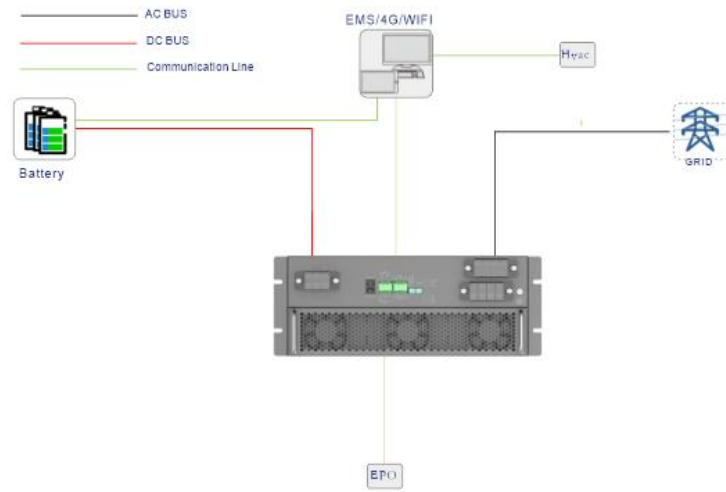

Picture 17

6.4. Energy storage+emergency standby power

Main application scenarios: EPS replacement, mobile power supply, battery cascade utilization, sodium ion battery, fuel cell, etc.

Main functions: support single-phase charging function, wide battery power full load range and maximum battery charging and discharging current 150A.

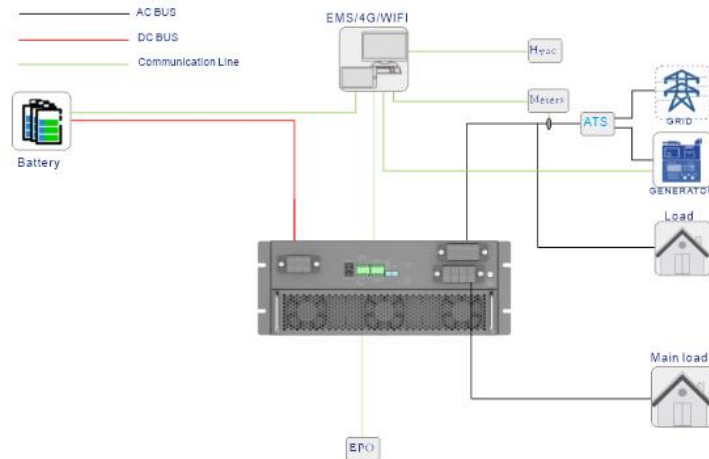

Picture 18

6.5. Multi-machine parallel scheme

Main functions: support multiple parallel machines, support transformer-free output, and support transformer startup.

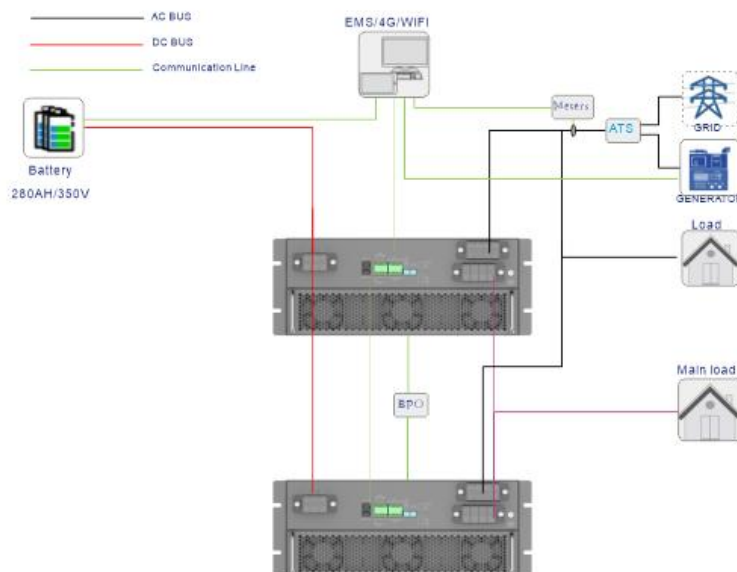

Picture 19

7. External EMS scheduling function (select to breed)

7.1. Introduction of microgrid EMS

Matching EMS series products can be selected, and the version is light storage diesel version of microgrid EMS. Micro-grid EMS is a key component to ensure the efficient, reliable and economical operation of the micro-grid, which is responsible for dispatching and managing distributed power generation resources, energy storage equipment, loads and possible grid-connection, off-grid and anti-reflux operations to ensure the stable and economical operation of the system.



Picture 20

7.2. EMS function

- Monitoring and data acquisition: real-time monitoring of energy flow in microgrid, including power generation, energy storage, photovoltaic and load. Collect and record key parameters, such as voltage, current, power and frequency, system diagnosis, cloud platform docking, etc.
- Control and optimization: optimize the operation of microgrid according to the energy demand and supply.
- Protection and safety: ensure the safe operation of microgrid, including overload protection, short circuit protection, equipment fault detection and response measures.
- Energy management: manage the energy distribution in the microgrid to ensure the effective use of energy and reduce waste, and may include demand response and peak-valley flattening

strategy.

- Economic dispatch: based on the change of electricity price and energy cost, economic dispatch is carried out to minimize the overall operating cost.
- User interaction: provides a user interface, allowing users to view energy usage, set operation mode and operation parameters.
- Grid connection and islanding operation: manage the grid connection and disconnection of microgrid and main grid.
- Remote OTA: It can diagnose EMS and inverter faults remotely and upgrade the software remotely.

7.3. EMS working model

economic pattern:

It is suitable for scenes with large peak-valley price difference.

In this mode, the charging and discharging time period is manually set, such as the low electricity price period at night is set as the charging time period, and the system charges the battery with the maximum charging power during this time period, so it is necessary to enable the "grid charging" function in the "energy storage control", and the high electricity price period is set as the discharging time period, so that the battery can be discharged only during the discharging time period, saving the electricity cost.

7.4. Other EMS parameter information

See EMS specification for details.