

SP30/25/15HBPS Series Microgrid Energy Storage Converter specification

Version: V1.7

Date: 04 February 2026



catalogue

1. product presentation	1
1.1. primary topology	1
1.2. Product Features	1
2. Product model and size	3
2.1. product model	3
2.2. naming rule	3
2.3. Product appearance and dimensions	4
3. Specification parameters	5
3.1. parameter	5
3.2. Power derating curve (battery voltage)	7
3.3. Power derating curve (grid voltage)	8
3.4. temperature derating curve	8
3.5. safe guarding	9
4. Port definition	9
5. Heat dissipation requirements	12
5.1. inlet and outlet air flow pattern	12
5.2. Heat dissipation requirements	13
6. application scenarios	13
6.1. Small-scale commercial energy storage	14
6.2. Off-grid Microgrid Solution	15
6.3. Three-phase unbalance and low voltage control	16
6.4. Energy Storage + Emergency Backup Power	16
6.5. multi-unit parallel scheme	17
7. External EMS scheduling (optional)	17
7.1. Introduction to EMS of Microgrid	17
7.2. EMS function	18
7.3. EMS work pattern	19
7.4. Other EMS parameters	19

1. product presentation

This high-efficiency and reliable energy storage converter is specifically designed for small and medium-sized energy storage microgrids. It features an integrated grid-connection/disconnection switching mechanism, supports multi-unit parallel operation, enables diesel generator hybrid operation, and allows rapid switching between grid-connected and off-grid modes. The solution is suitable for various applications including small commercial and industrial facilities, island microgrids, farms, villas, and battery reuse systems, meeting diverse user requirements.

1.1. primary topology

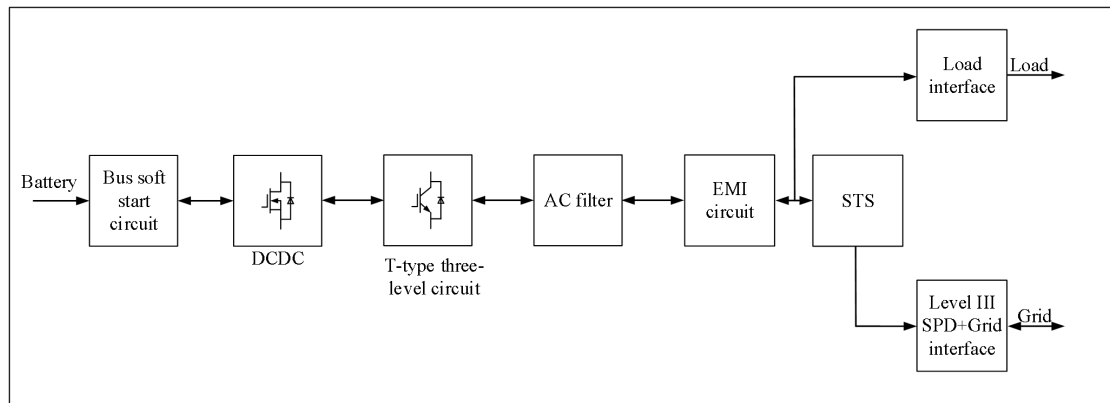

graph 1

1.2. Product Features

(1) Efficient and highly reliable:

- Low power consumption: standby power consumption $\leq 15W$, no-load operation loss $< 160W$.
- High efficiency: The maximum conversion efficiency reaches 97.8%.
- High Protection: The core control unit features IP5X-rated protection, ensuring stable operation in harsh environments including dust, high-salinity fog, and similar conditions.
- Air duct isolation design: The isolation air duct design enhances product safety and reliability.
- Exceeding overload capacity: With 150% instantaneous overload capacity, the system demonstrates enhanced adaptability and durability.

- Seamless switching capability: Enables seamless switching between grid-connected and off-grid modes, ensuring uninterrupted and stable power supply.

(2) function :

- Hybrid operation mode with diesel generator: Supports hybrid operation with diesel generator, providing flexible energy combinations to enhance energy efficiency.
- Three-phase independent grid-connected control technology: It realizes three-phase independent control, optimizes power distribution, and improves system flexibility and efficiency.
- Seamless switching: seamless on/off grid switching (less than 10ms);
- Grid adaptability: comprehensive high-low voltage crossing capability, island protection, and other functions;
- Parallel operation capability: The AC side supports 15 units running in parallel either on-grid or off-grid, while the DC side also enables multi-unit parallel operation.
- Versatile applications: Ideal for small businesses, island microgrids, farms, villas, and other scenarios, meeting diverse user needs.

(3) Convenience:

- Communication and Monitoring: Supports multiple communication protocols, including mainstream BMS protocols, enabling remote monitoring and management.
- High maintainability: front wiring and maintenance;
- Fault protection: comprehensive fault protection and fault recording functions;
- Wide voltage range: Compatible with various battery configurations, offering strong adaptability to meet diverse energy demands across different capacities. Enhanced battery compatibility and superior cost-effectiveness, with a minimum voltage of 200V, such as 30kW/20-70kWh (100AH) and 30kW/60-215kWh (280AH).

2. Product model and size

2.1. product model

SP30HBPS、SP25HBPS、SP15HBPS

2.2. naming rule

This document applies to the model specifications of SP**HB** series products.

NO.	code	meaning
1	corporate name	SP: Zhongteng Micro Network
2	alternating current rated power	30: Rated output power of AC 30kW 25: Rated output power of the AC system is 25kW 15: The rated output power of the AC is 15kW
3	DC voltage level	H: The DC input voltage ranges from 200 to 1000V.
4	Assembly method	B: Insert frame
5	Module Classification	G2: Hybrid Energy Storage Inverter PS: Energy storage converter DC: DC transformer PV: DC MPPT IV: dc-to-ac converter

2.3. Product appearance and dimensions

(1) product appearance

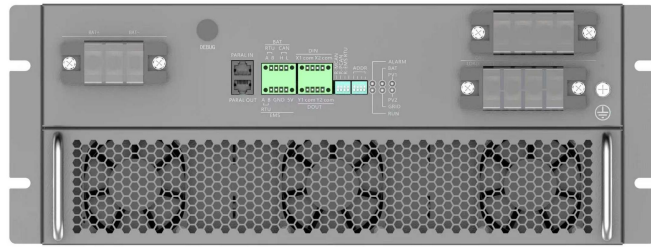

graph 2

(2) product size

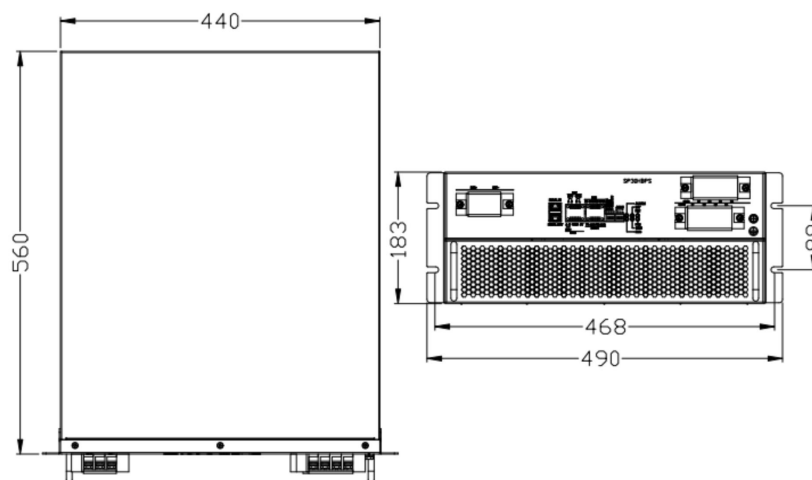

graph 3

3. Specification parameters

3.1. parameter

parameter	SP30HBPS	SP25HBPS	SP15HBPS
Battery parameters			
battery voltage range	200V-850V		
Supported battery types	lithium batteries, lead-acid batteries, etc.		
rated battery voltage range	320V-820V	320V-820V	200V-820V
maximum battery current	100A	80A	80A
AC side (grid connection)			
power rating	30kVA	25kVA	15kVA
rated current	43.5A	36.2A	22A
rated grid voltage	400V/230V		
grid voltage range	-20%~15%		
initiation current	8.5A		
power frequency range	50Hz (47Hz~52Hz) or 60Hz (57Hz~62Hz)		
current harmonics	<3%		
power factor	-1~1		
overvoltage class	II level		
Protection level	I level		
AC side (off-grid)			
output rating	30kVA	25kVA	15kVA
maximum output	33kVA	27.5kVA	16.5kVA
rated output current	43.5A	36.2A	22A
maximum output current	48A	40A	24.2A
rated voltage	400V/230V		
output voltage harmonics	<3% (resistive load)		
degree of unbalancedness	100%		
frequency range	50/60Hz		

maximum fault current	472A/20ms		
maximum protected current of AC	48A	39.8A	24.2A
Output overload (current) Ie: Rated output current	Ie*1.1<Iload≤Ie*1.25		100s
	Ie*1.25<Iload		300ms
	Ie*1.25<Iload		300ms
system parameter			
Communication port	EMS: RS485 Battery: CAN or RS485		
DIDO	DI: 2 channels; DO: 2 channels		
maximal efficiency	97.8%		
way to install	Insert Frame		
loss	Standby power <15W, no-load power <160W		
weight	≤35kg		
size	W*L*H: 440*560*183mm		
protect	IP20		
temperature range	-30 to 60°C (use with reduced capacity if temperature exceeds 45°C)		
Humidity range	5-95%		
cooling-down method	Smart fan speed control and air cooling		
class of pollution	II level		
height	4000m (use at reduced rate for distances over 2000m)		
attestation	CE, IEC62019, IEC62477, IEC61000, EN50549-1, AS4777.2		
grid support	LVRT、HVRT、VSG		

3.2. Power derating curve (battery voltage)

(1) SP30/25HBPS Power Derating Curve

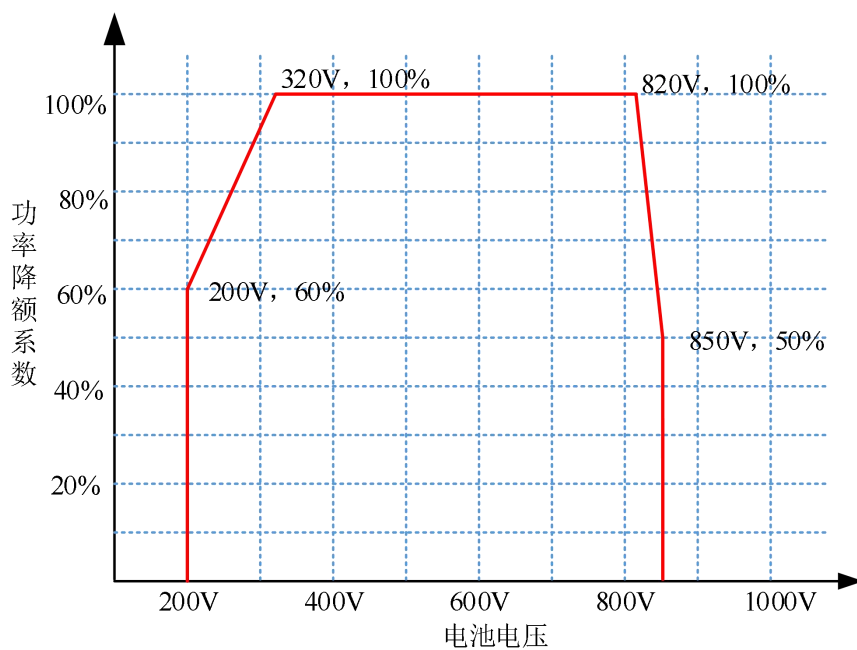

graph 4

(2) SP15HBPS Power Derating Curve

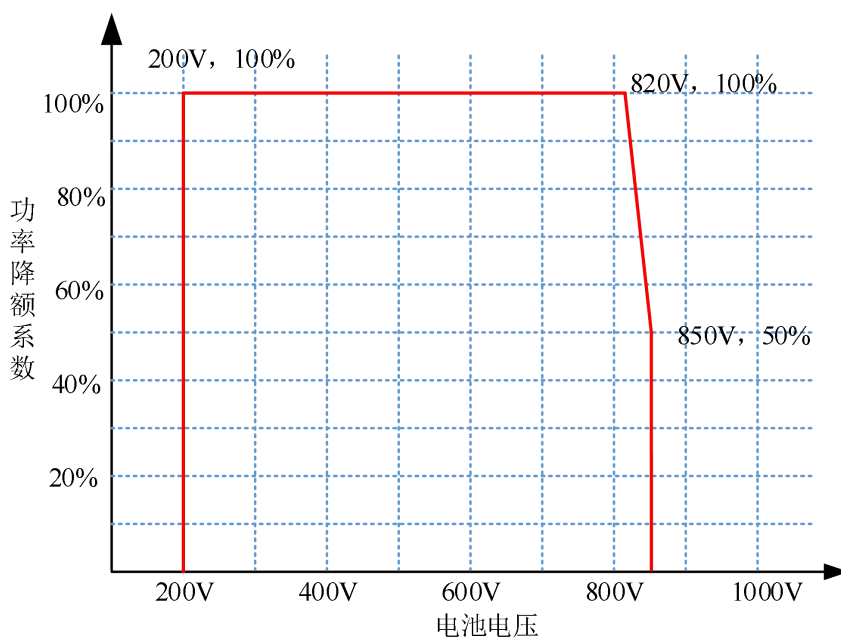

graph 5

3.3. Power derating curve (grid voltage)

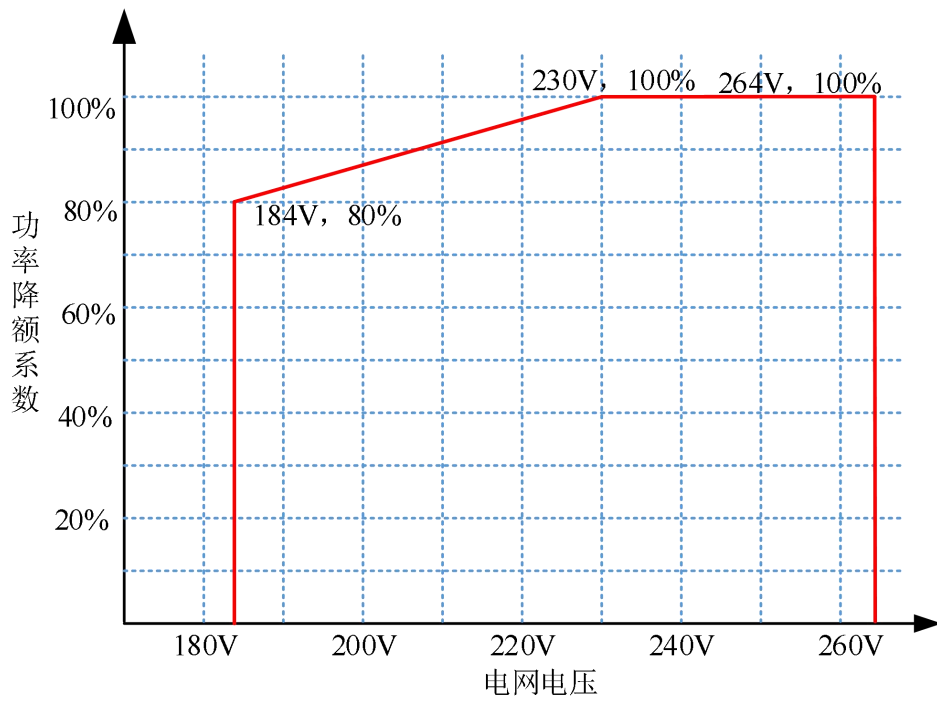

graph 6

3.4. temperature derating curve

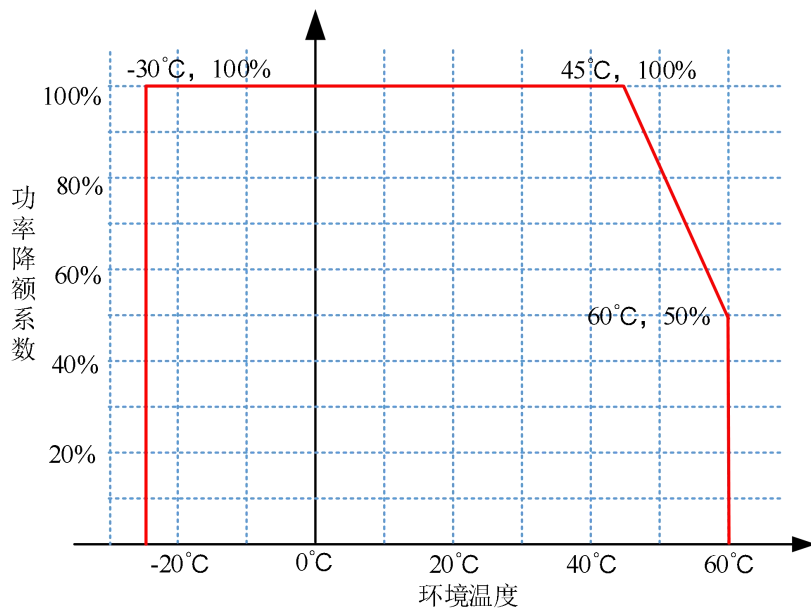

graph 7

3.5. safe guarding

- air duct isolation, anti-salt spray, and control chamber sealing;
- Humidity range 5%-95%;
- The system features 2KV ground fault immunity and Class III lightning protection. During PCS operation, either the AC side requires additional Class II lightning protection or the distribution unit must be equipped with it.
- The vibration test and the transportation test with packaging materials were carried out.

4. Port definition

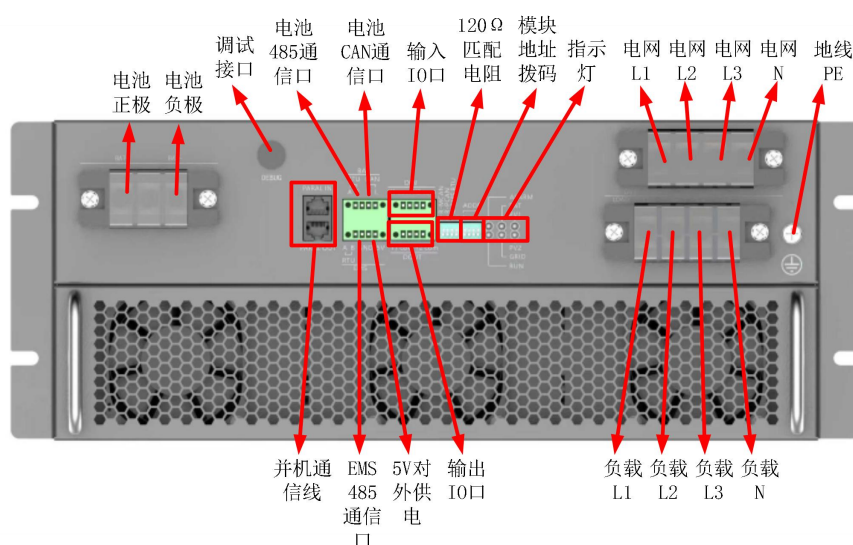

Figure 8 Port definition diagram

Power port definition:

name	function	remarks
BAT+/BAT-	battery input terminal	OT terminal (RNB22-6S), recommended 25mm ² cable
LOAD (L1/L2/L3/N)	AC load terminal	OT terminal (RNB22-6S), 16mm ² cable
GRID (L1/L2/L3/N)	AC power supply terminal	OT terminal (RNB22-6S), recommended 25mm ² cable
PE	earth terminal	OT terminal (RNB14-6S), recommended 10mm ² cable

⚠ take care

- The power terminal is secured with M6 screws. Use the included screws to fasten the power cable, applying a torque of 5.5-6.5 N·m. Excessive torque may damage the terminal, while insufficient torque may cause poor contact.
- The module must be reliably grounded during operation, as poor grounding may cause electric shock hazards and module damage. The fixing screw torque is 5 N·m.

The signal terminal interface definition is shown in Figure 9.

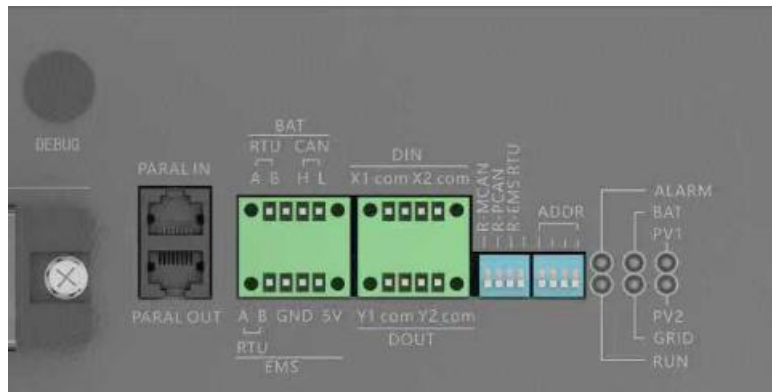

Figure 9 Signal Terminal Interface Definition

name	function	remarks
PARAL IN	parallel line input	parallel line
PARAL OUT	parallel line output	parallel line
BAT_RTU	Battery RS485 interface	BAT communication interface
BAT_CAN	Battery CAN interface	
RTU(A-B)	EMS communication interface	The host computer, EMS, or SAEMS100 (optional) coordinates the control system.
5V-GND	SAEMS power supply port	Output capacity: 5V/1A
X1	input dry node	scram button
X1_com	input dry node	
X2	input dry node	obligate
X2_com	input dry node	obligate
Y1	output dry contact	Output capability: The maximum voltage of the port is 24V, and the maximum current is 200mA.
com		
Y2	output dry contact	
com		

R-MCAN	parallel communication matching resistor	ON: indicates the communication matching resistor is connected
R-PCAN	parallel communication matching resistor	The first and last modules must be equipped with parallel communication matching resistors (set to ON via the dialer), while the rest need not.
R-EMS RTU	EMS RTU communication matching resistor	
ADDR	module address dial	ON: represents 1, otherwise 0 The module address is represented in binary format, with the left side being the high bit and the right side the low bit. For example, module 1 is represented as 0001, and module 3 as 0011.
DEBUG	debugging interface	For internal debugging only
ALARM	fault indicating lamp	The indicator light of the converter is on when it is faulty and off when it is not.
RUN	status indicator	The indicator light stays on during normal operation, flashes once per second in standby mode, and turns off when the converter malfunctions.
BAT	battery status indicator	The battery circuit function remains illuminated during normal operation. When the battery is functioning normally, it flashes once per second; when malfunctioning, it turns off.
GRID	power state indicator	The indicator stays on during grid-connected operation. It flashes once per second when the grid is normal, and turns off when grid abnormalities occur.
PV1	PV1 status indicator light	PV1 remains on during operation. When normal, it flashes once per second; when abnormal, it turns off.
PV2	PV2 status indicator light	PV2 remains illuminated during operation. When functioning normally, it flashes once per second; when malfunctioning, it turns off.

The internal schematic diagram of the output dry node is shown in Figure 10.

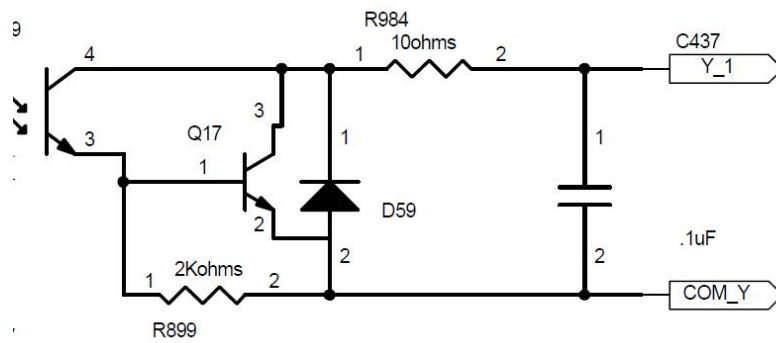

Figure 10: Internal Principle of Output Dry Node

The maximum voltage of the port is 24V, and the maximum current is 200mA.

The internal schematic diagram of the input dry node is shown in Figure 11.

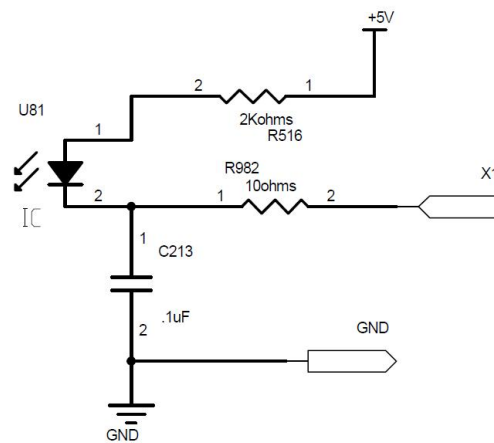
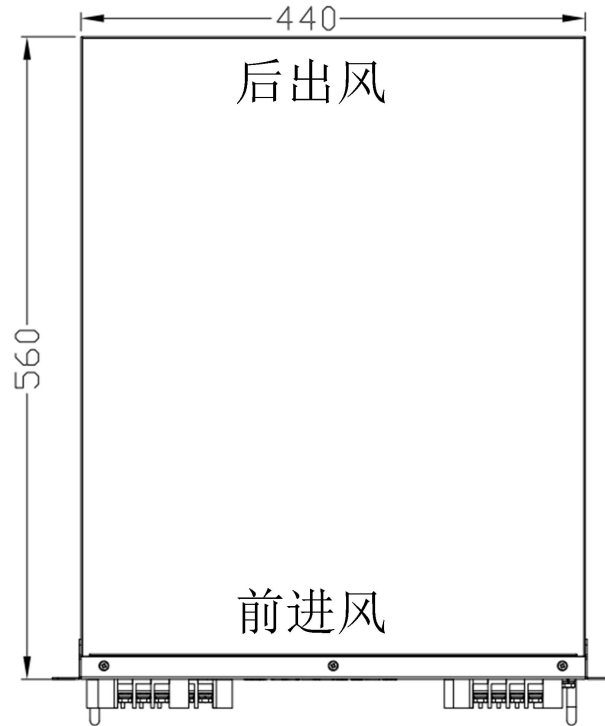

Figure 11 Internal schematic diagram of the input dry node

The input dry terminal is pre-installed with a power supply, requiring only an external switch for short-circuit connection. The total impedance of the switch and line must be less than 0.1Ω.

5. Heat dissipation requirements

5.1. inlet and outlet air flow pattern



graph 12

5.2. Heat dissipation requirements

The converter module employs forced air cooling with the front panel serving as the air intake and the rear panel as the exhaust outlet. The module's rated air intake capacity is 350 CFM (10m³/min). When installed in an integrated system, the cabinet's air intake must directly face the module's front intake, with a minimum distance of 110mm between the intake and cabinet enclosure. The cabinet should also incorporate dedicated air ducts and exhaust ports aligned with the module's exhaust and the cabinet's outlet, maintaining a minimum distance of 110mm to ensure direct airflow discharge and prevent internal recirculation. Where dedicated exhaust ports are unavailable, a fan should be installed at the cabinet's outlet, with airflow capacity twice the module's intake requirement. To accommodate dustproof padding, the cabinet's intake area should be three times larger than the module's intake area, using 40PPI polyurethane mesh foam with 94V0 flame retardancy rating. The cabinet's exhaust area should double the module's exhaust area, equipped with a 10-mesh insect-proof steel mesh. Refer to Figure 12 for intake specifications.

6. application scenarios

- Small-scale commercial and industrial facilities: Designed for small factories, commercial buildings, and office complexes, these systems optimize energy consumption through peak-valley pricing to reduce electricity costs. They also provide emergency backup power, ensuring critical equipment continues to operate smoothly during grid instability.
- Microgrid for Small Islands: In remote islands or areas without stable grid coverage, renewable energy sources like wind turbines can be integrated to establish independent microgrids, ensuring reliable power supply.
- Farms and agricultural facilities: Provide electricity for irrigation, greenhouse control, automated equipment, and support the oil engine hybrid mode to ensure operations continue even when energy is insufficient;
- Villas and residences: providing energy solutions for high-end residences, while also offering emergency power supply to households, ensuring uninterrupted electricity in case of grid failures;
- Temporary power supply and construction sites: These systems can serve as portable power sources for construction sites, outdoor activities, and temporary facilities, providing essential electricity support. They also support hybrid diesel generator systems to ensure uninterrupted power supply.
- Remote areas and emergency rescue: In remote areas or emergency rescue scenarios, lightweight, highly integrated, and rapidly deployable systems provide stable power supply to support the operation of critical facilities such as communication equipment and medical devices.
- Battery recycling: Participate in national or regional energy optimization projects, such as wind-solar-diesel-storage island demonstration projects, to demonstrate the performance and benefits of SP30HBPS in real-world applications.

6.1. Small-scale commercial energy storage

Main application scenarios: homes, villas, supermarkets, farms, and outdoor construction sites.

Main functions: emergency backup power supply, etc.

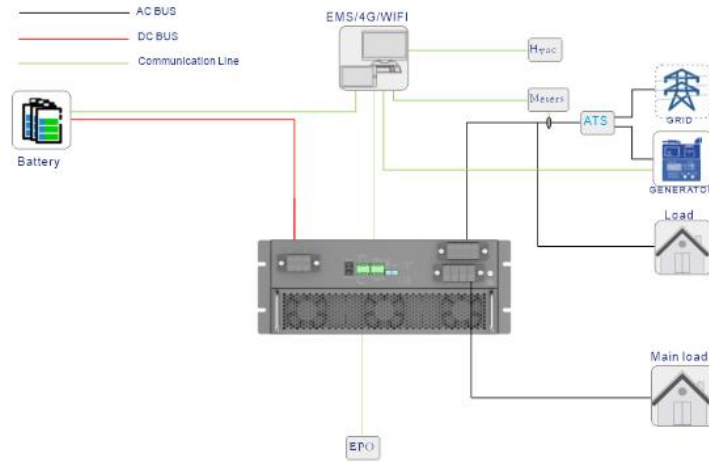

graph 13

6.2. Off-grid Microgrid Solution

Main application scenarios: power instability areas, villas, farms, islands, oil extraction, and other off-grid regions.

Key functions: emergency backup power, generator management, fan management, etc.

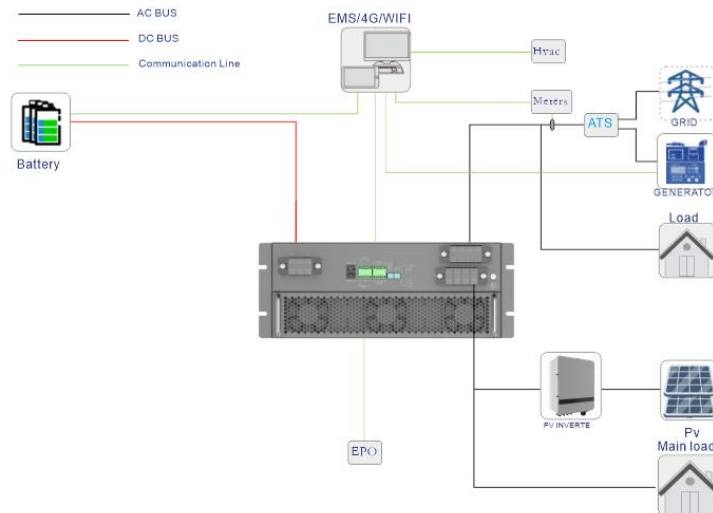

graph 14

6.3. Three-phase unbalance and low voltage control

Key application scenarios: Terminal grid voltage issues (e.g., high/low/imbalance) caused by renewable energy integration, load fluctuations, or line impedance.

Key features: Three-phase independent grid connection with autonomous control, ensuring energy balance and maximum compensation of 150%.

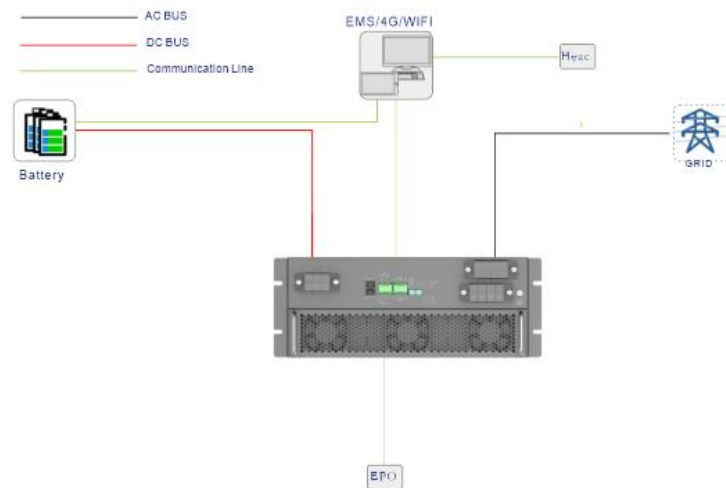

graph 15

6.4. Energy Storage + Emergency Backup Power

Key applications: EPS replacement, power banks, battery recycling, sodium-ion batteries, fuel cells, and more.

Key features: Supports single-phase charging with a wide power range and a maximum current of 100A.

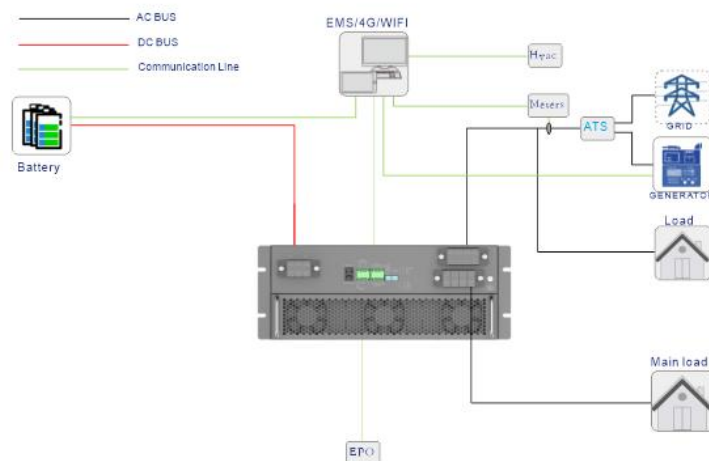

graph 16

6.5. multi-unit parallel scheme

Key features: Supports multi-unit parallel operation, transformerless output, and transformer-based startup.

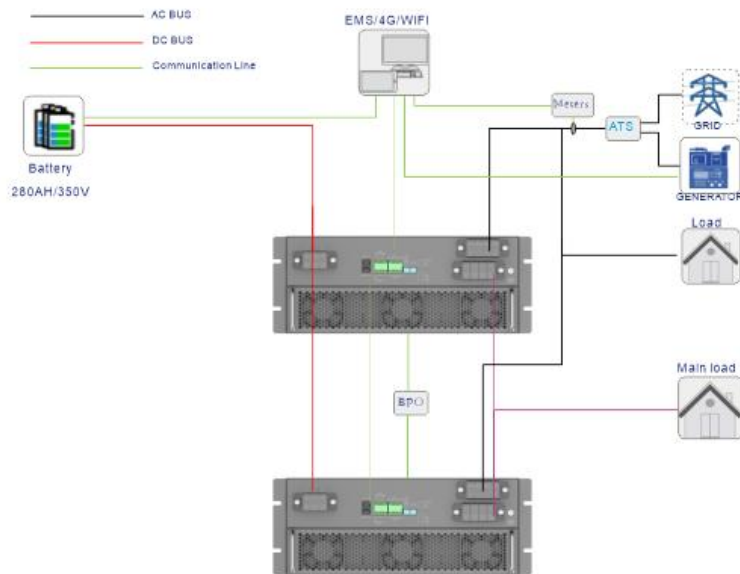

graph 17

7. External EMS scheduling (optional)

7.1. Introduction to EMS of Microgrid

The optional EMS system is available in the PV-storage-diesel microgrid EMS version. As a critical component, the microgrid EMS ensures efficient, reliable, and cost-effective operation by managing distributed generation resources, energy storage devices, loads, and potential grid-connected or off-grid operations with anti-feeding-back functionality, thereby maintaining system stability and economic performance.



graph 18

7.2. EMS function

- **Monitoring and Data Acquisition:** Real-time monitoring of energy flow in microgrids, including power generation, energy storage, photovoltaic systems, and load conditions. Collect and record key parameters such as voltage, current, power, and frequency. System diagnostics and cloud platform integration are also supported.
- **Control and Optimization:** Optimize microgrid operations based on energy demand and supply conditions.
- **Protection and Safety:** Ensuring secure operation of microgrids, including overload protection, short-circuit protection, equipment fault detection, and response measures.
- **Energy Management:** Manages energy distribution in microgrids to ensure efficient utilization and minimize waste, potentially incorporating demand response and peak shaving strategies.
- **Economic Scheduling:** A process that optimizes power generation based on electricity price fluctuations and energy costs to minimize overall operational expenses.
- **User interaction:** Provides a user interface to view energy usage, set operation modes, and adjust operational parameters.
- **Grid connection and island operation:** manage the connection and disconnection operations between microgrid and main grid.
- **Remote OTA:** Enables remote diagnostics for EMS and inverter faults, and software

upgrades remotely

7.3. EMS work pattern

(1) economic pattern :

It is suitable for scenarios with large peak-valley price difference.

This mode allows manual configuration of charging/discharging windows. For instance, the system charges batteries at maximum power during off-peak nighttime hours by enabling the 'Grid Charging' feature in Energy Storage Control. Meanwhile, high-cost electricity hours are designated as discharge windows, restricting battery discharge to these periods to optimize energy expenditure.

7.4. Other EMS parameters

See the EMS specification for details