

SP105HCDC Inverter

User Manual



Version: V1.3

Release Date: October 14, 2025

Table of Contents

1 Manual Description	1
1.1 Applicable Products	1
1.2 Applicable Personnel	1
1.3 Symbol Definitions	1
2 Safety Precautions	2
2.1 General Description	2
2.2 PV String Safety	2
2.3 Battery Safety	4
2.4 Personnel Requirements	4
2.5 Operational Safety	4
3 Product Introduction	5
3.1 Product Features	5
3.1.1 Product Positioning	5
3.1.2 Product Advantages	5
3.1.3 Specifications	6
3.1.4 Product Operating Characteristic Curves	7
3.2 Model Number Rule Explanation	8
3.3 Product Circuit Introduction	9
3.3.1 Main Topology	9
3.4 Product Structure	9
4 Transportation, Storage, and Installation	10
4.1 Transportation and Storage	10
4.2 Unpacking and Inspection	11
4.3 Handling and Installation	12
4.3.1 Installation and Handling Precautions	12
4.3.2 Installation Tools	13
4.3.3 Installation Environment	13
5 Cable Connection Instructions	15
5.1 Port Definitions	15

5.2 High-Voltage Side Connection	19
5.3 PV Side Connection	20
6 Power On/Off Operations and Fault Diagnosis	22
6.1 Power On/Off Operations	22
6.1.1 Initial Power-On and Post-Maintenance Power-On Steps	22
6.1.2 Pre-Maintenance Power-Off Steps	22
6.2 Fault Diagnosis and Resolution	23
7 PC Software Installation and Use	28

1 Manual Description

This document primarily introduces the product information, installation wiring, configuration commissioning, fault troubleshooting, and maintenance content of the hybrid inverter. Please read this manual carefully before installing and using this product to understand the product safety information and familiarize yourself with the product's functions and features. The document may be updated periodically; please obtain the latest version of the documentation and more product information from the official website.

1.1 Applicable Products

This document applies to the following models of hybrid inverters:



SP105HCDC1、SP105HCDC4

1.2 Applicable Personnel

Applicable only to professionals who are familiar with local regulations and standards, electrical systems, have received professional training, and possess in-depth knowledge of this product.

1.3 Symbol Definitions

To better use this manual, the following symbols are used to highlight relevant important information. Please read the symbols and explanations carefully.

 DANGER	
●	Indicates a highly potential hazard which, if not avoided, will result in death or serious injury.
 WARNING	
●	Indicates a medium potential hazard which, if not avoided, could result in death or serious injury.
 CAUTION	
●	Indicates a low potential hazard which, if not avoided, could result in moderate or minor injury.
NOTE	
●	Emphasis and supplement to the content, may also provide tips or tricks for optimal product use, helping you solve a problem or save time.

2 Safety Precautions

The safety precaution information contained in this document must always be followed when operating the inverter.

NOTE

- The inverters covered in this document have been strictly designed and tested in accordance with safety regulations. However, as electrical equipment, relevant safety instructions must be followed before performing any operation on the inverter. Improper operation may lead to serious injury or property damage.

2.1 General Description

NOTE

- Due to inverter version upgrades or other reasons, the document content will be updated periodically. Unless otherwise agreed, the document content cannot replace the safety precautions on the product label. All descriptions in the document are for guidance only.
- Please read this document carefully before installing the inverter to understand the inverter and precautions.
- All operations on the inverter must be performed by professional, qualified electrical technicians who are familiar with the relevant standards and safety regulations of the project location.
- Damage to the inverter or personal injury caused by failure to install, use, or configure the inverter in accordance with the requirements of this document or the corresponding user manual is not within the scope of the inverter manufacturer's responsibility.

2.2 PV String Safety









WARNING

- Ensure that the component frames and bracket system are well grounded.
- After the PV input cable connection is completed, ensure the cable connections are tight and secure, with no looseness.

- Use a multimeter to measure the positive and negative poles of the PV input cable to ensure the connection polarity is correct and the voltage is within the allowable range.
- Do not connect the same PV string to multiple inverters, as this may cause inverter damage.

 **DANGER**

- When installing the inverter, avoid letting the inverter's connectors bear weight, otherwise it may lead to connector damage.
- After inverter installation, the labels and warning signs on the inverter must be clearly visible; obscuring, altering, or damaging them is prohibited.
- The identifiers on the inverter are as follows:

	High Voltage Hazard. High voltage exists when the inverter is running. When operating on the inverter, ensure the inverter is powered off.		Delayed Discharge. After powering off the inverter, please wait 15 minutes for the inverter to fully discharge.
	Read the inverter's related instructions carefully before operating the inverter.		Potential hazard exists after the inverter starts running. Take precautions during operation.
	The inverter surface is hot. Do not touch the inverter while it is running, otherwise it may cause burns.		Protective Earth (PE) connection point.
	CE Mark		The inverter cannot be disposed of as household waste. Please dispose of the inverter according to local laws and regulations, or return it to the inverter manufacturer.

2.3 Battery Safety

WARNING

- Before installing the battery pack, carefully read the battery pack user manual to understand the product and precautions, and strictly follow the requirements in the battery pack user manual for operation.
- If the battery pack is fully discharged, strictly follow the requirements in the battery pack user manual to charge the battery pack.
- The output capability of the battery pack can be affected by environmental factors such as temperature, humidity, and weather conditions, which may limit the battery pack's output capability and thus limit the inverter's load capacity.
- If the battery pack cannot start, contact after-sales service as soon as possible, otherwise it may cause permanent damage to the battery pack.
- Use a multimeter to measure the positive and negative poles of the battery pack output cables to ensure correct polarity connection between the battery pack output cables and the inverter's battery input interface; and ensure the battery pack output voltage is within the allowable range of the inverter's battery input voltage.

2.4 Personnel Requirements

NOTE

- Personnel responsible for installing or maintaining the hybrid inverter must be strictly trained, understand various safety precautions, and master the correct operation method of the hybrid inverter.
- Only qualified professionals or trained personnel are allowed to install, operate, maintain, and repair the hybrid inverter.

2.5 Operational Safety

When operating the inverter, operators must use insulated tools and wear safety protective equipment to ensure personal safety.

3 Product Introduction

3.1 Product Features

3.1.1 Product Positioning

The device primarily utilizes third-generation semiconductors, featuring a compact size and high efficiency. It employs an isolated air duct design for excellent environmental adaptability. Mainly used for battery charging and discharging, it supports multiple operating modes including CC, CV, and CP at both the battery and bus ends, with 0ms switching between modes. Capable of parallel operation with multiple units, it integrates seamlessly with inverters, supporting grid-tied/off-grid inverter operation and rapid switching between charging and discharging modes.

3.1.2 Product Advantages

- 1) High efficiency, high reliability
 - Low power consumption: Standby power <15W, no-load running loss <100W.
 - Fast optimization: Optimization step size 1s, quickly finds the maximum power point. High efficiency: Maximum conversion efficiency 99.3%.
 - High protection: Uses an isolated air duct design scheme, core control part has IP5X protection rating.
 - High reliability: Supports complete disconnection between the battery and inverter in case of battery or inverter abnormality.
- 2) Functions:
 - Parallel operation: Supports parallel use of up to 15 units, single unit can be controlled independently.
- 3) Ease of use:
 - High versatility: Supports multiple communication protocols, supports mainstream BMS protocols, can be connected to EMS systems for remote monitoring and management.
 - High maintainability: Front wiring, front maintenance.
 - Fault protection: Comprehensive fault protection and fault recording functions.
 - Wide input voltage range: Wide input voltage range, strong adaptability, able to meet energy

needs of different capacities.

3.1.3 Specifications

(1) Product Parameters

Parameter	SP105HCDC1	SP105HCDC4
PV Parameters		
Rated Power	105kW	105kW
PV Open Circuit Voltage Range	200V-900V	
MPPT Voltage Range	525V	
Rated Voltage	1	4
Startup Voltage	200A	50A+50A+50A+50A
High-Voltage Side Parameters		
Voltage Range	500V-950V	
Rated Voltage	680V	
Max Current	180A	
System Parameters		
Communication Ports	EMS: RS485 Battery: CAN or RS485	
DIDO	DI: 2 channels, DO: 2 channels	
Maximum Efficiency	99.3%	
Installation Method	Chassis Mount	
Losses	Standby <15W, No-load <100W	
Weight	29KG	
Dimensions	W * H * D: 440*183*560mm	
Protection	IP20	
Temperature Range	-30~60℃ (Derating above 45℃)	
Humidity Range	5%~95%	
Cooling Method	Intelligent Forced Air Cooling	

Noise	50dB
Altitude	4000m (Derating above 2000m)
保护	Overtemperature protection, Overcurrent protection, Overvoltage protection, Ground short-circuit protection
认证	CE, IEC62477, IEC62109, IEC6100
Soft-start circuitry	Yes

3.1.4 Product Operating Characteristic Curves

1) SP105HDC1/SP105HDC4 power derating factor

Battery Voltage

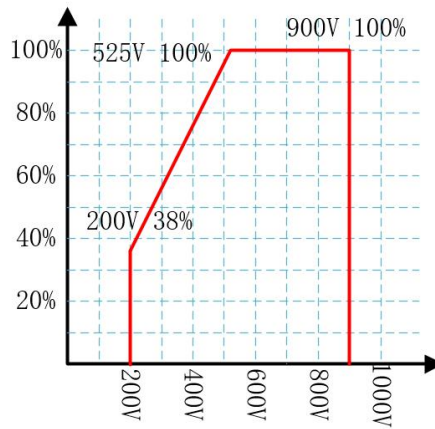

Figures 1

High-side voltage

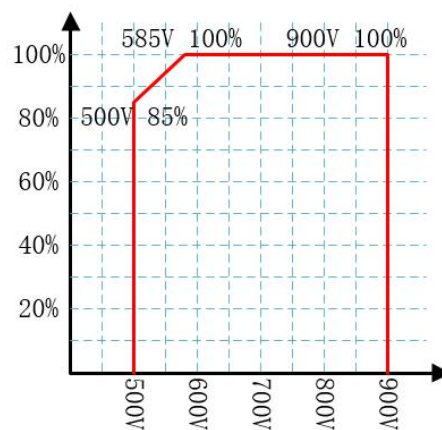

Figures 2

2) Temperature Derating Curve:

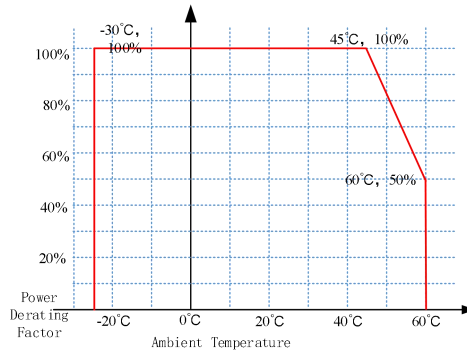

Figures 3

3) Safety Protection

- Air duct isolation, anti-salt spray, control compartment sealing.
- Humidity range 5%-95%.
- Immunity 2KV to ground. If the length of the high/low voltage side cables exceeds 20M during application, it is recommended to add a DC lightning arrester.
- Operating vibration test, transportation test with packaging.

3.2 Model Number Rule Explanation

This document applies to the model number explanation of the SPHC series inverters.

No.	Code	Meaning
1	Company Name	SP: Sinosoar
2	AC Rated Power	60: AC rated output power 60kW 50: AC rated output power 50kW 40: AC rated output power 40kW 30: AC rated output power 30kW
3	DC Voltage Level	H: DC side input voltage within 200~1000V
4	Installation Method	C: Chassis Mount
5	Module Classification	G2: Hybrid Storage Inverter PS: Storage Inverter DC: DC Converter

		PV: DC MPPT IV: Inverter
--	--	-----------------------------

3.3 Product Circuit Introduction

3.3.1 Main Topology

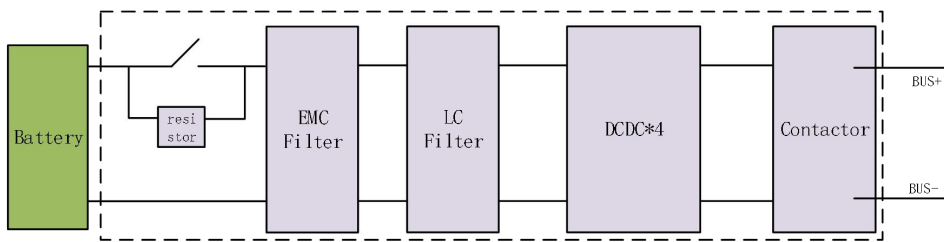

Figures 4

3.4 Product Structure

1) SP105HCDC1 Product Appearance

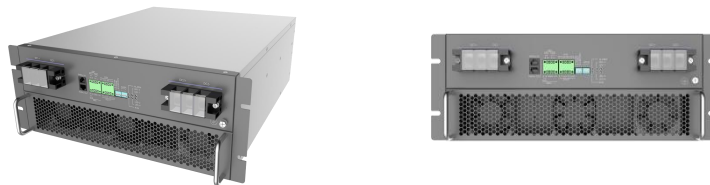

Figures 5

2) SP105HCDC4 Product Appearance

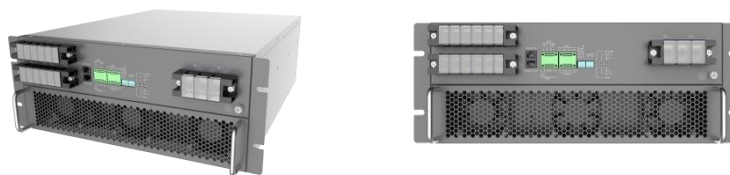

Figures 6

3) SP105HCDC1 Product Dimensions

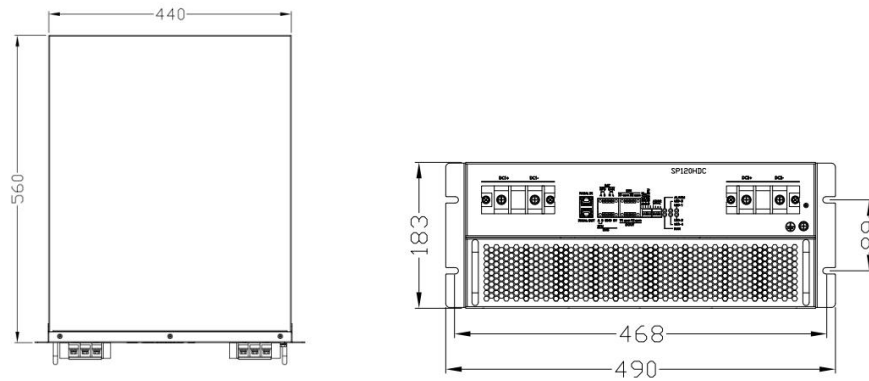

Figures 7

4) SP105HCDC4 Product Dimensions:

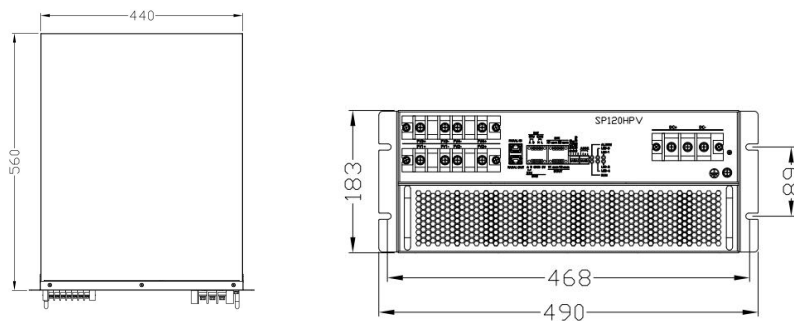

Figures 8

4 Transportation, Storage, and Installation

4.1 Transportation and Storage



When transporting and storing the inverter module, please pay attention to the markings on the packaging box. The transportation and storage process should meet the following requirements:

! CAUTION

- Ensure that the inverter's outer packaging is not removed during storage and transportation;
- Ensure the storage environment is free of corrosive and toxic gases;
- Ensure the storage temperature is maintained between -45°C and 70°C , and the relative humidity is maintained between 5%RH and 95%RH;
- Ensure a maximum stacking of 4 layers during storage, and ensure the stack has no risk of

- tipping over;
- Regular inspections are required during storage; if insect or rodent damage is found, the packaging materials should be replaced promptly;
 - Ensure the transportation vehicle and storage warehouse meet fire safety requirements;
 - If the storage time exceeds six months, the inverter must be inspected and tested by professionals before being put into use;
 - Avoid transporting the inverter in rainy or bad weather conditions; if unavoidable, be sure to take necessary protective measures;
 - If long-term storage is required, ensure that from the date of purchase, the inverter is powered on once a year, and each power-on time is not less than 6 hours.

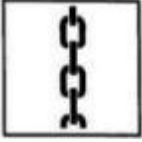
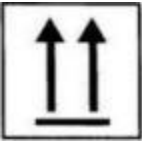
Packaging mark illustrations are explained in the table below:

Icon	Description
	Center of gravity mark, indicating the location of the center of gravity of the energy storage inverter.
	Lifting mark, indicating the position of the chain or rope when hoisting the energy storage inverter.
	Upwards mark, indicating the placement orientation when handling and placing the energy storage inverter. Inverting, horizontal placement, or tilting is strictly prohibited.
	Handle with care mark. Avoid severe friction or collision during transportation and placement.
	Keep dry mark. The energy storage inverter should be protected from rain or moisture during transportation and storage.

4.2 Unpacking and Inspection

When unpacking the inverter, the following checks need to be performed:

 **WARNING**

- Before unpacking, check if the inverter's outer packaging is damaged. If damaged, please contact relevant personnel promptly for confirmation and replacement;
- Place the inverter on a level surface with the front facing up, and remove the outer packaging's sealing tape;
- Take out the shipping accessories and confirm whether there is any missing or incorrect shipment of accessories. If there is any missing or incorrect shipment, please contact relevant personnel promptly for confirmation and supplementation of the relevant accessories;
- Remove the cushioning foam, then require two or more people to assist each other in taking out the inverter module to prevent the inverter from falling during removal, threatening life and property safety;
- Check if the plastic film packaging bag of the inverter module is damaged. If damaged, please contact relevant personnel promptly for confirmation and replacement;
- Remove the plastic film from the module, and check the module's appearance for obvious scratches or defects. If obvious scratches or defects are found, please contact relevant personnel promptly for confirmation and replacement;
- Check if the parameters on the inverter module's nameplate match the purchase order, such as model, rated power, voltage range, and other key parameters. If the parameters on the inverter module's nameplate do not match the purchase order, please contact relevant personnel promptly for confirmation and replacement;
- Dispose of the inverter-related packaging materials reasonably according to local laws and regulations.

4.3 Handling and Installation



4.3.1 Installation and Handling Precautions

During the transportation, storage, or installation of the inverter, the laws, regulations, and relevant standards of the country and region must be met. Before installation, the hybrid inverter needs to be moved to the installation site. To avoid personal injury or equipment damage during

the handling process, please note the following:

 WARNING	
<ul style="list-style-type: none"> ● Please assign personnel according to the weight of the hybrid inverter to avoid injury caused by the weight exceeding the human handling capacity. ● When installing or handling the hybrid inverter, please wear safety gloves to avoid injury. ● Ensure the inverter remains balanced during handling to avoid falling. 	

4.3.2 Installation Tools

Tools		
Forklift	Torque Wrench	Screwdriver
 For short-distance movement of equipment, use a forklift to avoid dropping during handling, causing personal injury or equipment damage.	 When connecting power cables, use a torque wrench to fix according to the relevant torque value to prevent poor connection between the power cable and the terminal due to insufficient torque or terminal damage due to excessive torque.	 Cross-head screwdriver M6 screw, used for fixing the module in the cabinet.

4.3.3 Installation Environment

The installation environment of the inverter needs to meet the following conditions:

 CAUTION	
<ul style="list-style-type: none"> ● The inverter must be installed in a location with shelter to avoid direct sunlight; ● The inverter should be installed in a well-ventilated place to prevent affecting its working performance due to poor heat dissipation; ● During operation, the surface temperature of the inverter is high, so it must be installed in a 	

position that is not easily touched;

- The inverter must be kept away from children and special populations;
- The installation area of the inverter should be away from flammable and explosive materials, and away from strong interference equipment;
- The installation rack or wall for the inverter should have certain fire resistance;
- The inverter should avoid being installed near noise-sensitive office areas or residential places.

To ensure the safety of installation personnel, relevant safety protection measures must be in place when performing electrical installation or maintenance on this product. During electrical installation, the following regulations must be followed:

 **DANGER**

- All power sources connected to the inverter must be disconnected to ensure the inverter is in a de-energized state.
- Warning signs must be left at the disconnected positions to prevent re-energization during installation.
- Necessary grounding and short-circuit connections must be made.
- Live parts must be treated accordingly and isolated with insulating materials to avoid harm to personnel.
- Only professionals can perform installation operations on the inverter, and the installation process must strictly follow the user manual guidance.
- Installation personnel must comply with the relevant electrical operating procedures of the country or region.
- Installation personnel need to understand the voltage level of the power supply area and judge the voltage compatibility.

The environmental requirements for the inverter are as follows:

 CAUTION	
●	This product is for installation inside a cabinet and needs to be installed in the final system for use;
●	The installation altitude should not be higher than 4000m; derating is required above 2000m, and use is prohibited above 4000m;
●	The inverter operating ambient temperature is -30°C to $+60^{\circ}\text{C}$; when the ambient temperature is $>45^{\circ}\text{C}$, the inverter needs to be derated;
●	The inverter operating ambient humidity is 5%RH to 95%RH, without condensation;
●	When the inverter operates in a high-dust environment, a dust filtration device needs to be added according to the site conditions, but it should not affect the inverter's air intake and exhaust volume;

5 Cable Connection Instructions

5.1 Port Definitions

Power Port Definitions:

SP105HCDC4:

Name	Function	Remarks
DC2+/DC2-	High-Voltage Side Terminal	OT Terminal (RNB50-6S), Recommended 50mm ² Cable
BAT1+/BAT1-	Battery Side Terminal	OT Terminal (RNB10-6S), Recommended 10mm ² Cable
BAT2+/BAT2-	Battery Side Terminal	OT Terminal (RNB10-6S), Recommended 10mm ² Cable
BAT3+/BAT3-	Battery Side Terminal	OT Terminal (RNB10-6S), Recommended 10mm ² Cable
BAT4+/BAT4-	Battery Side Terminal	OT Terminal (RNB10-6S), Recommended 10mm ² Cable

SP105HCDC1:

Name	Function	Remarks
DC1+/DC1-	Battery Side Terminal	OT Terminal (RNB50-6S), Recommended 50mm ² Cable
DC2+/DC2-	High-Voltage Side Terminal	OT Terminal (RNB50-6S), Recommended 50mm ² Cable

⚠ CAUTION

- The power terminals on the high-voltage side and PV side use M6 screws for fixation. Please use the screws provided with the product to fix the power cables, and the fixing screw torque is 5.5~6.5N · m. Excessive torque can damage the terminal, while insufficient torque can lead to poor contact.
- The module must be reliably grounded during operation. Poor grounding may lead to electric shock hazard and module damage. The fixing screw torque for grounding is 5 N · m.

Signal Terminal Interface Definitions as shown in Figure 18:

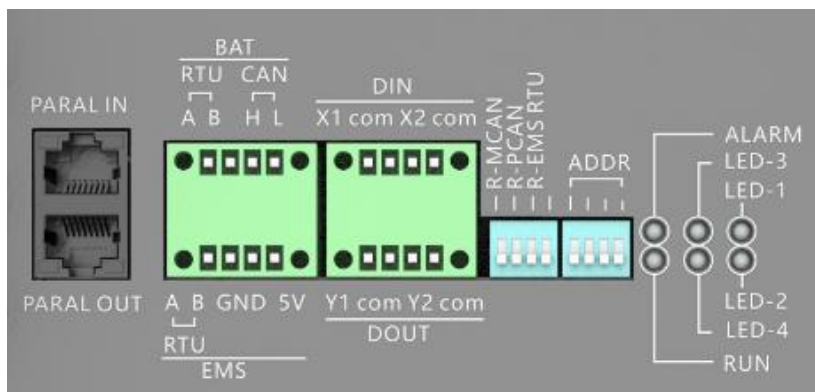

Figures 9

Name	Function	Remarks
PARAL IN	Parallel Connection Input	Parallel Cable
PARAL OUT	Parallel Connection Output	Parallel Cable

BAT_RTU	Battery RS485 Interface	BAT Communication Interface
BAT_CAN	Battery CAN Interface	
RTU(A-B)	Customer RS485 Interface	EMS Communication Interface
X1	Dry Contact Input	EPO+
X1_com	Dry Contact Input Common	EPO-
X2	Dry Contact Input	Reserved
X2_com	Dry Contact Input Common	Reserved
Y1	Output Dry Contact	DOUT
com	Common	
Y2	Output Dry Contact	
com	Common	
R-MCAN	Parallel Communication Matching Resistor	ON when switch is up. Set to ON for the first module and the last module.
R-PCAN	Parallel Communication Matching Resistor	
R-EMS RTU	EMS RTU Communication Matching Resistor	
ADDR	Module Address DIP Switch	ON when switch is up. Address 00001 means address 1. Address 00100 means address 4.
ALARM	Fault Indicator	
RUN	Status Indicator	
LED-1	PV1 Status Indicator	

LED-2	PV2 Status Indicator	
LED-3	PV3 Status Indicator	
LED-4	PV4 Status Indicator	

Output Dry Contact Internal Schematic as shown in Figure 10:

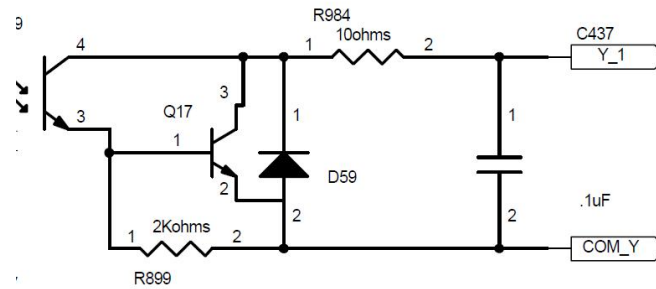

Figures 10

Note: The port maximum voltage should not exceed 24V, and the maximum current should not exceed 200mA.



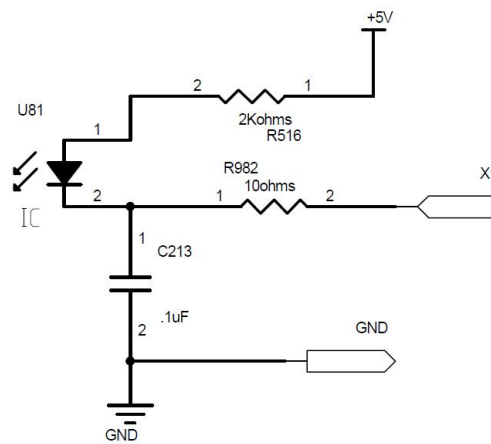



Input Dry Contact Internal Schematic as shown in Figure 11:



Figures 11

Note: The input dry contact has a built-in power supply. The external side only needs to provide a switch for shorting. The sum of the switch short-circuit impedance and the line impedance should be less than 0.1Ω .

Cable Connection Tools

Tools and Instruments		
Multimeter  Measure equipment live status	Torque Wrench  Connect power cables, torque 3 N • m (30 kgf • cm)	Crimping Tool  For power cable crimping
Screwdriver  Cross-head screwdriver for fastening and removing M6 screws	Wire Stripper  For power cable processing	Heat Gun (or Hot Air Blower), Heat Shrink Tubing  Cover the conductive part of the power cable to avoid leakage

Appropriately add relevant tools according to the site conditions to avoid affecting the installation progress due to lack of tools.

5.2 High-Voltage Side Connection

 WARNING
<ul style="list-style-type: none"> ● The high-voltage side voltage must not exceed the inverter's allowed rated voltage range, otherwise it may cause equipment damage; ● When a ground fault exists in the system, the ground fault must be eliminated before proceeding with wiring; ● The DC power cable screws of the inverter must be tightened according to an installation torque of 3 N • m. Less than this torque may cause fire due to poor contact, and greater than this torque may cause power terminal damage; ● Incorrect wiring of the inverter will cause the inverter to fail to work properly, or even lead

to equipment damage;

- During installation, strictly follow the cable installation sequence to prevent accidents.

The installation sequence for high-voltage side cables is as follows:

Step 1: Use a multimeter to measure the battery port voltage, ensuring the battery voltage is within the inverter's voltage range.

Step 2: Disconnect the battery switch, and use a multimeter to confirm that the power cables to be installed to the inverter are in a de-energized state.

Step 3: Cut heat shrink tubing to a suitable length and assemble it onto the power cable to be crimped.

Step 4: Use a wire stripper to strip the insulation of the power cable to a suitable length, then put on the corresponding cold-press terminal, and finally use a crimping tool to crimp the terminal tightly.

Step 5: After the terminal is crimped, check if the crimp is reliable. If not reliable enough, cut off the terminal and repeat Step 4.

Step 6: After the terminal is reliably crimped, use a heat gun to shrink the heat shrink tubing, providing proper insulation.

Step 7: Connect the positive and negative power cables of the battery pack to the inverter's terminal "DC2+" and "DC2-". Use a torque wrench to calibrate the installation torque to ensure good contact between the power cable and the power terminal.

5.3 PV Side Connection

WARNING

- The PV side voltage must not exceed the inverter's maximum allowed rated voltage range, otherwise it may cause equipment damage;
- When a ground fault exists in the system, the ground fault must be eliminated before proceeding with wiring;
- The PV power cable screws of the inverter must be tightened according to an installation torque of 3 N • m. Less than this torque may cause fire due to poor contact, and greater than this torque may cause power terminal damage;
- During installation, if the phase sequence is wrong, it will cause the inverter to fail to work

properly, or even damage the inverter;

- During installation, strictly follow the cable installation sequence to prevent accidents.

The installation sequence for PV side power cables is as follows:

Step 1: Use a multimeter to measure the PV port voltage, ensuring the PV voltage is within the inverter's input voltage range.

Step 2: Disconnect the grid switch, use a multimeter to measure the PV side cables and the inverter's PV side terminals, confirming that the PV cables to be installed to the inverter and the inverter's PV side terminals are in a de-energized state.

Step 3: Cut heat shrink tubing to a suitable length and assemble it onto the power cable to be crimped.

Step 4: Use a wire stripper to strip the insulation of the power cable to a suitable length, then put on the corresponding cold-press terminal, and finally use a crimping tool to crimp the terminal tightly.

Step 5: After the terminal is crimped, check if the crimp is reliable. If not reliable enough, cut off the terminal and repeat Step 4.

Step 6: After the terminal is reliably crimped, use a heat gun to shrink the heat shrink tubing, providing proper insulation.

Step 7: Connect the positive and negative power cables of the PV array to the inverter's terminal "DC1+" and "DC1-". Use a torque wrench to calibrate the installation torque to ensure good contact between the power cable and the power terminal.

6 Power On/Off Operations and Fault Diagnosis

6.1 Power On/Off Operations

6.1.1 Initial Power-On and Post-Maintenance Power-On Steps

(1) Power-On Startup

Step 1: Use a multimeter set to DC voltage to test the PV voltage. Check if the PV voltage is within the PV voltage range required by the inverter. If the PV voltage is greater than the required range, reduce the number of PV modules in series to bring the PV voltage within the required range. If the PV voltage is less than the required range (under good light conditions), increase the number of PV modules in series to bring the PV voltage within the required range.

Step 2: Close the circuit breaker on the PV side of the inverter. Wait 10 seconds and observe if the PV status indicator on the inverter front panel is flashing. If the PV status indicator is not flashing, use a multimeter in DC voltage mode to measure the voltage at the inverter's PV port to see if it is within the required PV voltage range. If it is not within the range, check if the relevant power cables are correctly connected and if there is reverse polarity at the PV port cables. If no cable reverse polarity is found after checking and the PV port voltage is within the required range, contact the relevant inverter personnel for handling.

Step 3: Send the PV startup command to the inverter. Wait 20 seconds. The PV status indicator should change from flashing at 1-second intervals to a steady light. If the status indicator does not become steady, check if the startup command was sent successfully and if the communication protocol matches (it can be configured to start automatically when PV conditions are met).

6.1.2 Pre-Maintenance Power-Off Steps

(2) Power-Off Shutdown

Step 1: Send the shutdown command. Observe if the PV status indicator on the inverter front panel is flashing at 1-second intervals or is off. If the PV status indicator remains steadily lit, check if there is an issue with the communication protocol with the inverter and if the shutdown command was successfully sent. If there are no issues, contact the relevant inverter personnel for handling.

Step 2: Disconnect the PV port circuit breaker and hang a "Under Maintenance, Do Not Energize" sign at the breaker. At this point, the inverter fault indicator should be steadily lit, and the PV status indicator should be off.

Step 3: Use a multimeter set to DC voltage test mode and AC voltage test mode to measure the voltage between the positive and negative poles of the PV port. Wait until the voltage drops below 60V. If it is above 60V, continue waiting until the port voltage drops below 60V before proceeding.

Step 4: Wait 15 minutes for the internal discharge of the inverter to complete.

Step 5: Use a phone to take photos to record the cable connection relationships to prevent incorrect reconnection after maintenance.

Step 6: Disconnect the power cables and communication cables connected to the inverter. Use insulating tape to insulate and protect the cable ends.

Step 7: Two or more people must work together to remove the inverter for maintenance and inspection. It is strictly prohibited for one person to perform maintenance and inspection on the inverter alone.

6.2 Fault Diagnosis and Resolution

1、 Alarm/Fault Codes and Troubleshooting Measures

1) Module faults are divided into several categories. Specific categories and troubleshooting measures are shown in the table below:

Alarm or Fault Name	Fault Code	Shut down	Recovery Method	Troubleshooting Measures
Soft Start Failure	1	Shut down	Self-recovery	1. Power off the module, wait 1-2 minutes, then restart the module. 2. If the fault persists after the above operation, please contact Sinosoar customer service.

Address Duplicate/Invalid Address	3	Shut down	Check before startup, recover after power-off	<p>1. Power off the module, reselect a module address that is not duplicate on the system. Address range is #1~#10.</p> <p>2. Address range #1~#10. DIP switch from left to right, left is high bit, right is low bit. 'ON' position is valid, calculated in binary.</p> <p>3. After resetting the address, power off and restart to 生效.</p>
ECAP Fault	4	Shutdown	Self-recovery	<p>Check if the parallel communication cable between units is not connected properly. Reconnect the parallel communication cable. Replace the parallel communication cable.</p>
CPLD Cycle-by-Cycle Current Limit Fault	6	Shutdown	Self-recovery	<p>1. The machine experienced overcurrent. Check the load condition or wiring.</p>
Output Short Circuit	8	Shutdown	Self-recovery	<p>1. Power off the module, check if there is a short circuit at the output.</p>
Overload Protection	9	Shutdown	Self-recovery	<p>Long time in overload state, please check the load.</p>

Shutdown				
----------	--	--	--	--

2) Battery Faults

Alarm or Fault Name	Fault Code	Shut down?	Recovery Method	Troubleshooting Measures
Bus Overvoltage	18	Shutdown	Self-recovery	1. Check if the bus voltage is overvoltage. Power off, wait 1 minute, then power on again.
Bus Undervoltage	19	Shutdown	Self-recovery	1. Check if the bus voltage is undervoltage, or if the input voltage is too low. 2. Contact customer service.
DC Soft Start Failure	21	Shutdown	Self-recovery	1. Wait for the bus voltage to rise, then restart.
Battery Reverse Polarity	22	Shutdown	Self-recovery	1. Check if the battery positive and negative terminals are reversed.
Battery Overvoltage	23	Shutdown	Self-recovery	1. Check if the battery input is overvoltage. Power off, wait 1 minute, then power on again.
Battery Undervoltage	24	Shutdown	Self-recovery	1. Check if the battery input is undervoltage.
Discharge Overcurrent	25	Shutdown	Self-recovery	1. Check if there is overcurrent during discharge.
Charge Overcurrent	26	Shutdown	Self-recovery	1. Check if there is overcurrent

				during charging.
DC Contactor Fault	32	Shutdown	Self-recovery	1. PTC abnormal or DC contactor abnormal.

3) System Faults

Alarm or Fault Name	Fault Code	Shutdown?	Recovery Method	Troubleshooting Measures
Fan Fault	50	No Shutdown	Alarm, Self-recovery	1. Check if the fan is damaged.
Mode Error	52	Shutdown	Self-recovery	1. Phase lock failure in VF mode.
Auxiliary Power Abnormal	53	Shutdown	Self-recovery	1. Check if the auxiliary power voltage is too low.
SysFault	54	Shutdown	Self-recovery	1. Other faults reported, causing shutdown. To eliminate this fault, other faults must be eliminated first.
Arm Fault	55	Shutdown	Self-recovery	1. Check if the address DIP switch is set wrong, or if communication is interrupted, emergency stop fault, etc.
Overtemperature Fault	57	Shutdown	Self-recovery	1. Check if the machine environment temperature is too high. Enhance ventilation.

IGBT Temperature Abnormal	58	Shutdown	Self-recovery	1. Check if the temperature difference between the three IGBTs is too large.
Flash Initialization Error	59	Shutdown	Self-recovery	1. EEPROM chip initialization failed.
Internal Communication Fault	61	Shutdown	Self-recovery	1. Check if the connection between DSP and ARM is unstable or disconnected. 2. Check if the DSP or ARM has no program.
CPLD Abnormal	64	Shutdown	Self-recovery	1. CPLD hardware version number abnormal.

7 PC Software Installation and Use

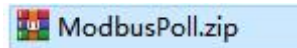

1) Software Installation

Step 1: Extract the installation package ModbusPoll.zip.



Figures 12

Step 2: Install the 32-bit or 64-bit version according to your computer's

	ModbusPollSetup32Bit	2015/7/21 20:00	应用程序	1,588 KB
	ModbusPollSetup64Bit	2015/7/21 20:00	应用程序	1,692 KB

Figures 13

Step 3: Follow the prompts to install.

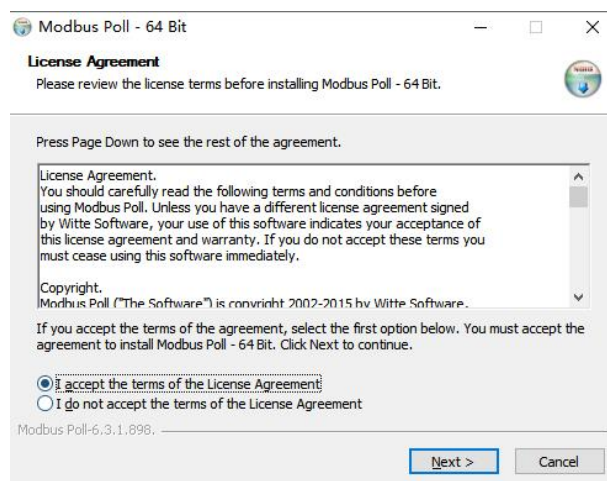

Figures 14

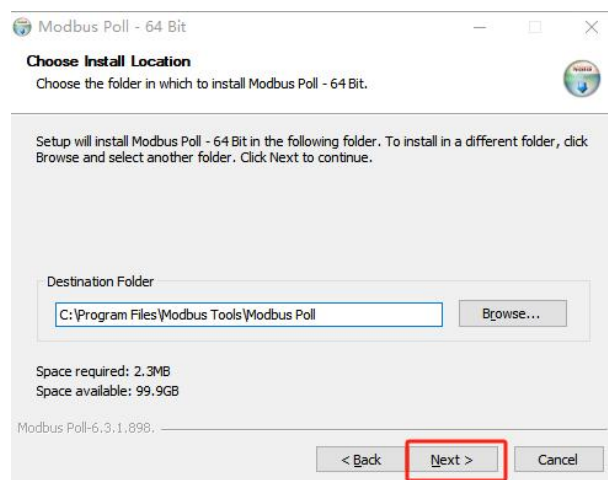

Figures 15

Step 4: After successful software installation, a shortcut will be created on the desktop.



Figures 16

2) Communication Connection

Use a 485 debugging tool to connect to the EMS's RTU communication port.

3) Software Debugging Function

a) Communication Connection Page

Step 1: Double-click to open the software.

Step 2: Open the corresponding template file.

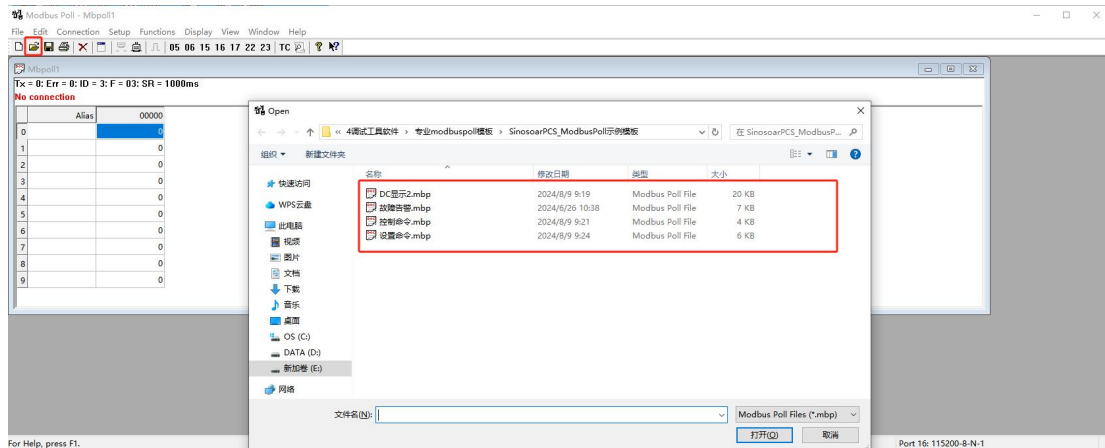

Figures 17

Step 3: Communication connection, select the corresponding serial port and baud rate.

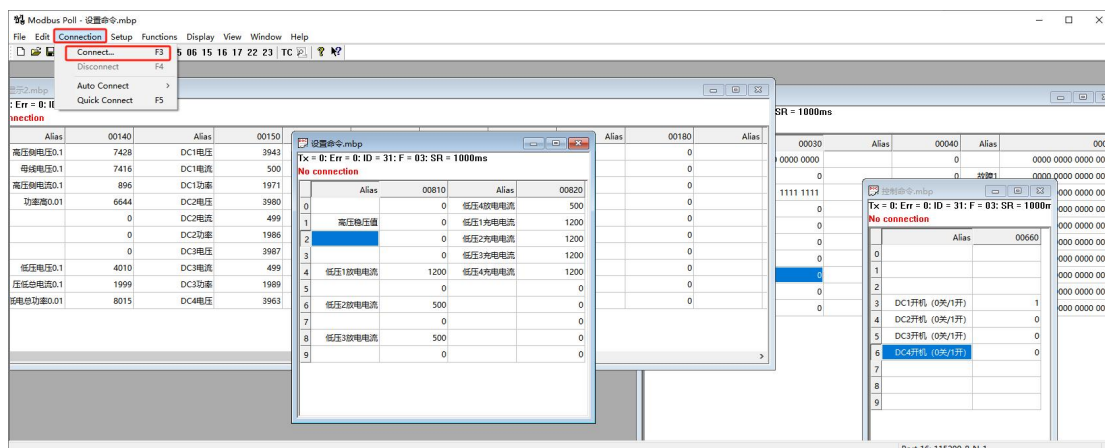

Figures 18

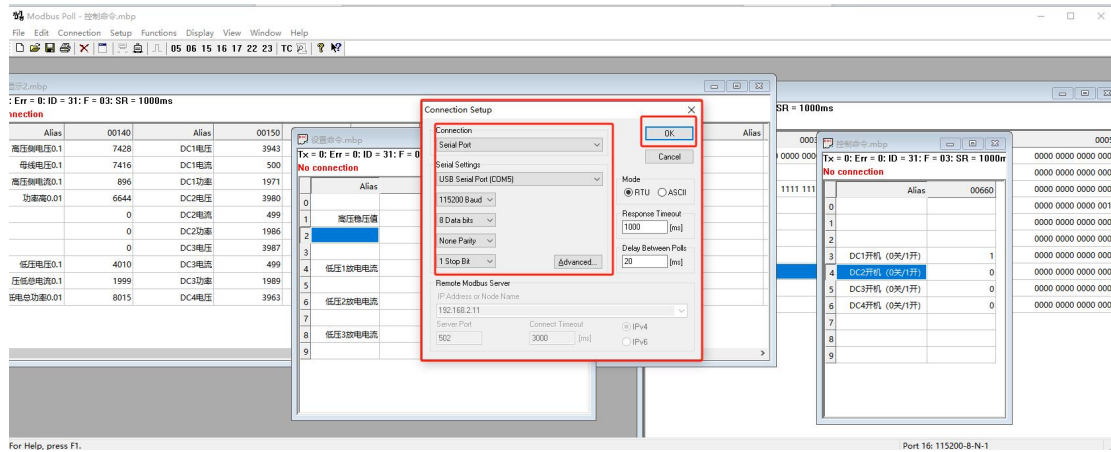

Figures 19

b) Display Interface

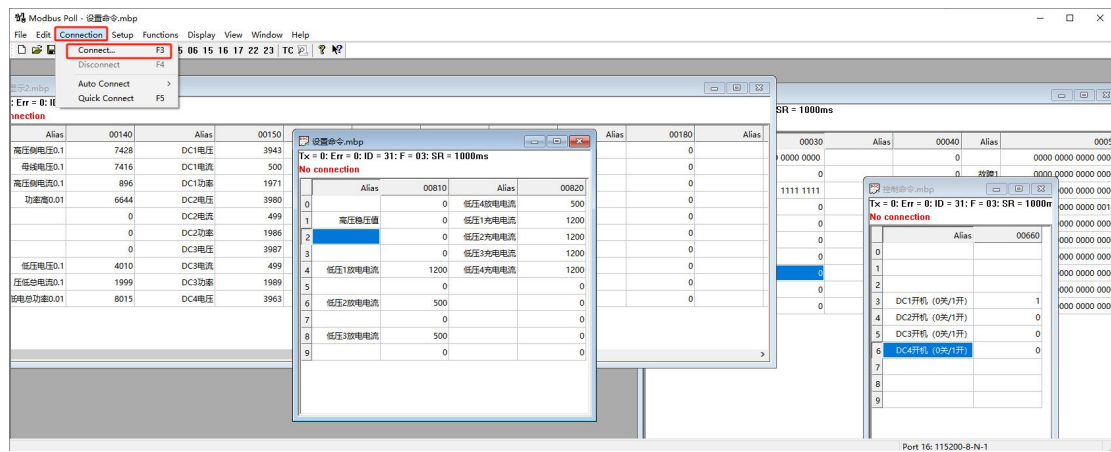

Figures 20

There are four panels respectively: Display, Control, Settings, and Fault.