

SAEMS User Manual

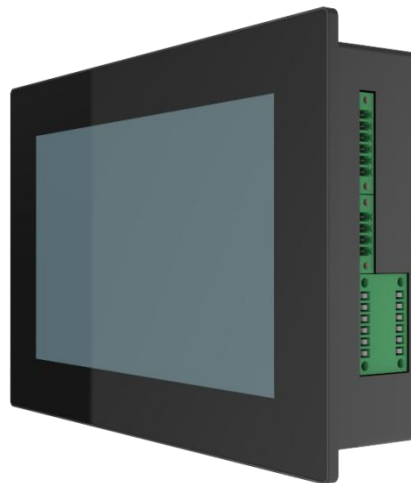

Version: V1.0

Release date: July 28,2025

Table of Contents

I. Local display instructions	1
1. EMS operation flow chart	1
2. Home page interface description	2
3. Local EMS Settings	3
3.1. Basic Settings Notes	3
3.2. Select inverter model	4
3.3. Battery configuration	4
3.3.1. Lithium battery configuration	4
3.3.2. Lead-acid battery configuration (only for self-use)	5
3.4. Work mode configuration	6
3.4.1. Set up self-use mode	6
3.4.2. Set the surplus power on the Internet mode	6
3.4.3. Set the time function	7
3.4.4. Set the self-use + backup power mode	7
3.4.5. Set the meter to anti-flow mode	8
3.5. Meter configuration	8
3.6. Automatic activation of diesel generator configuration	9
3.7. Weak grid configuration	10
3.8. Multi-machine parallel configuration	11
3.9. Air conditioning information and configuration	13
3.10. PCS emergency stop configuration	14
3.11. Charging module configuration	14
3.12. Single-phase charging function configuration	15
3.13. Dry contact configuration	15
3.13.1. Indicator light configuration	15
3.13.2. EMS emergency stop, switch on/off configuration	16
3.13.3. Enter DI custom configuration	17
3.13.4. Custom output DO configuration	19
3.14. Other display interface description	20
3.15. Check for faults and troubleshoot	22
3.15.1. Check for system failures	22
3.15.2. Refer to the table for fault information	22
II. Cloud Platform Configuration and Description	32
1. 4G/Wifi communication stick	32
1.1. product appearance	32
1.2. Product interface	33
2. Mobile (APP) cloud platform	34
2.1. Step 1: Register and log in to the APP	34
2.2. Step 2: Connect the Wifi stick to the network	35
2.3. Add 4G/WiFi communication stick devices to the mobile terminal (APP terminal)	35
2.3.1. Add a WiFi version of the communication stick	35
2.3.2. Add 4G version communication stick	36
2.3.3. Mobile phone APP remote control device	37
2.3.4. Mobile APP page description	38
3. PC (web) cloud platform	39
3.1. Add 4G/WiFi communication stick devices to PC (web)	39
3.2. View system data on the PC (web)	41
III. Wiring instructions	43
1. EMS interface diagram and definition	43
2. EMS wiring diagram	46
4. Screen program refresh (screen upgrade)	47
1. Preparations for the burn	47
2. Burn screen files	49

I. Local display instructions

1. EMS operation flow chart

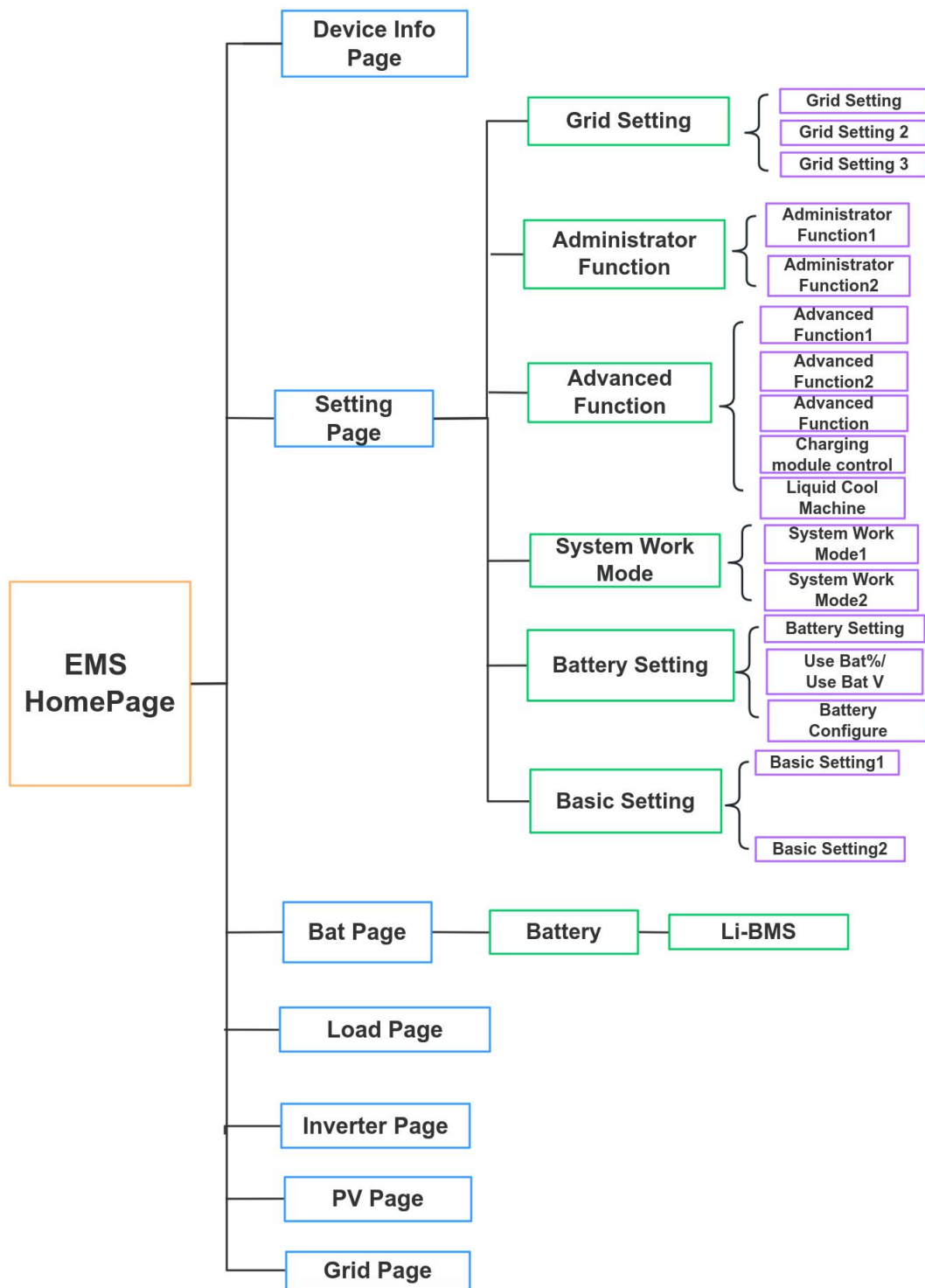

Figure 1
1

2. Home page interface description

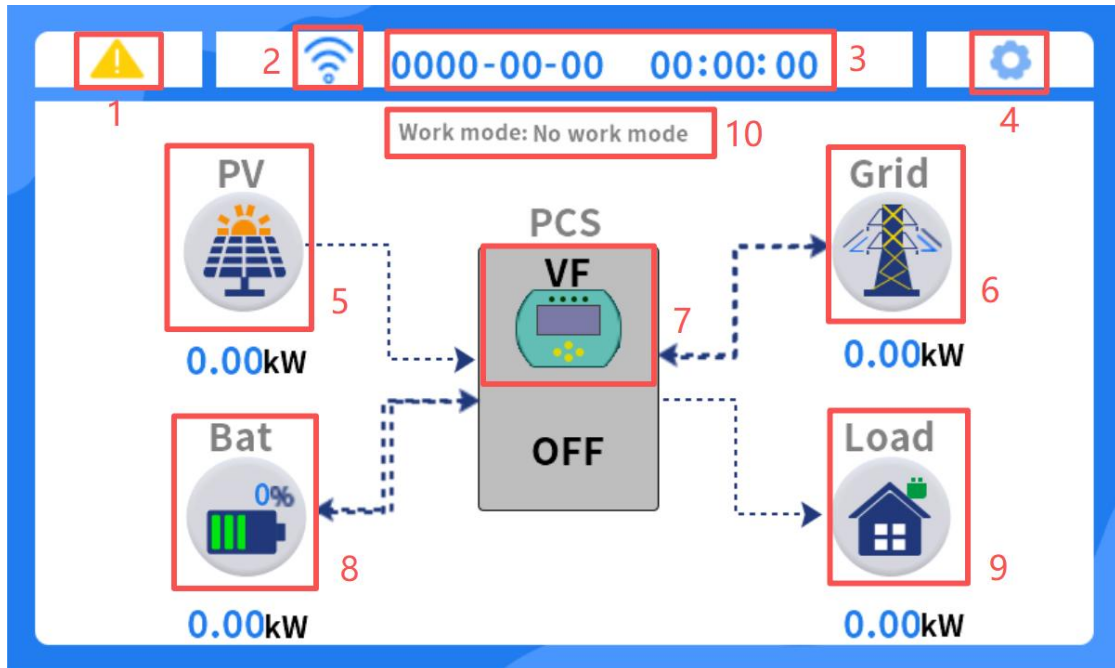



Figure 2. Homepage description

Corresponding instructions are shown in the sequence number above

- 1) **Fault/warning:** When the icon is gray, there is no warning or fault. When the icon is yellow, there is a warning. When the icon is red, there is a fault.
- 2) **WIFI icon:** shows whether the communication bar is online. If the communication bar is online, the WIFI icon is blue; if the communication bar is offline, the WIFI icon is gray.
- 3) **Time display**
- 4) **Set the button:** Click this button to enter the Settings interface.
- 5) **Photovoltaic part:** including photovoltaic power, photovoltaic icon and energy flow. Click the photovoltaic icon to enter the photovoltaic detailed information interface.
- 6) **Power grid:** includes power grid power (positive value is the power supply of converter, negative value is the discharge of converter), energy flow and power grid icon. Click the power grid icon to enter the detailed information interface of the power grid.
- 7) **Converter section:** Click the converter icon to enter the converter detailed information interface when the converter is turned on (the converter icon is green) and when the converter is turned off (the converter icon is gray).
- 8) **Battery section:** includes battery power (positive value is discharge, negative value is discharge), energy flow, battery SOC and battery icon. Click the battery icon to enter the battery details interface.
- 9) **Load section:** includes load power, energy flow and load icon. Click the load icon to enter the load details interface.
- 10) **Working mode section:** real-time display of EMS current working mode.

3. Local EMS Settings

Home screen → Settings icon  in the upper right corner to enter the Settings screen.

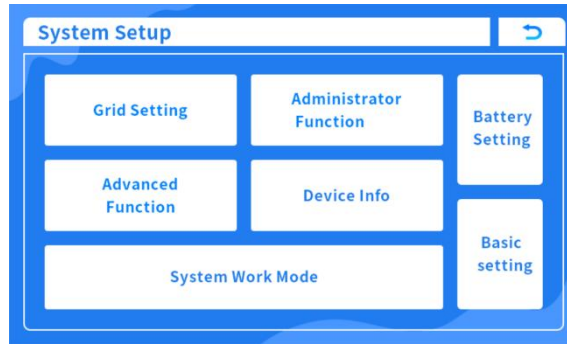



Figure 3 sets the page

3.1. Basic Settings Notes

How to enter the basic Settings interface: Main interface  → Settings  icon in the upper right corner → Basic Settings.

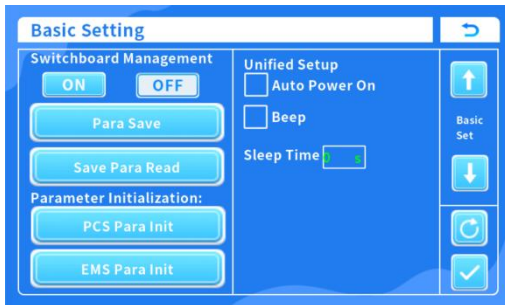

Figure 4 Basic Settings Page 1



Figure 5 Basic Settings Page 2

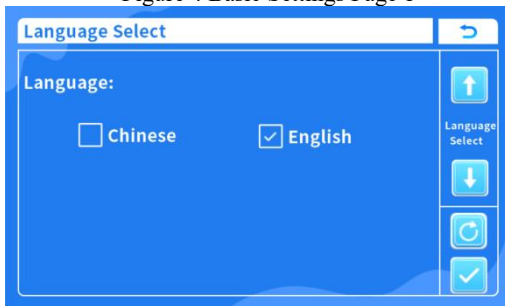



Figure 6 basic Settings page 3

Power on: Click  ON.

Shut down: Click OFF  to shut down.

Automatic power on/off: Check  Auto Power On. When checked, clicking the button will make a sound; when unchecked, clicking the button will be silent.



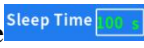



Beeper:  Beep. When checked, clicking the button will make a sound; when unchecked, clicking the button will be silent.

Sleep time: : Set the screen to turn off when no operation is performed.

Previous/Next: Click or  scroll  up/down.

Save Settings: Click  Save Parameters  to check whether the saved values are effective.
Page 2: Time Settings.
Page 3: Language Settings, currently supports Chinese and English.

3.2. Select inverter model

Home screen → Settings icon  in the upper right corner → Advanced Function  → PCS/System Config  → PCS Quantity:  Select the number of converters, which is default to 1. When an EMS connects multiple inverters, select the corresponding number → Select the model  and click save parameters .

Model 对照表:

Screen display model	Plate number
SP30HBG2	SP30HBG2/SP25HBG2/SP15HBG2/SP30HBPS/SP25HBPS//SP15HBPS
SP60HCG2	SP60HCG2/SP60HCPS
SP50HCG2	SP50HCG2/SP50HCPS
SP100H+STS+MPPT/D CDC	SP100HC/SP125HCPS+STS200/PCM170/PCM330+SP120HCPV
SP100+STS	SP100HC/SP125HCPS+STS200/PCM170/PCM330
SP100H+MPPT/DCDC	SP100HC/SP125HCP+SP120HCPV

3.3. Battery configuration



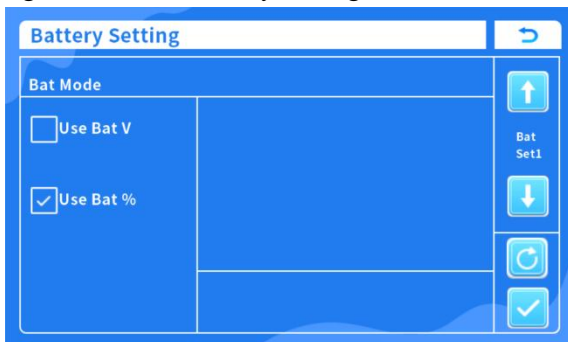

How to enter the battery SOC setting interface: main interface →  Settings icon in the upper right corner → Battery Settings



(FIG.) Basic Settings Page 1

Select battery mode, use battery voltage and use battery SOC. Usually lead-acid batteries choose battery voltage mode, lithium batteries choose battery SOC mode.

3.3.1. Lithium battery configuration

Battery SOC mode setting: check the use of battery SOC  →  click the previous page to three pages to select the battery protocol  Non-functional, after selecting the battery protocol click save the setting ; click to enter the second page battery SOC setting interface.

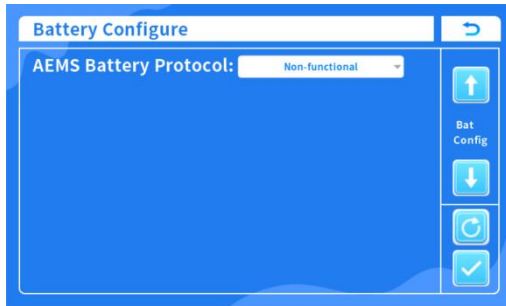

Figure 7 Battery protocol configuration



Figure 8 Battery SOC configuration

Battery SOC Settings interface description:

Stop chg: The battery is charged to the cutoff SOC (the actual SOC of the battery is \geq the set value). When the SOC reaches this threshold, the charging will stop regardless of photovoltaic or grid.

Differential Return: Restore the charging stop backoff value. Charging resumes when the actual battery SOC falls below the set charging stop SOC-backoff value. For example, if the charging stop threshold is set to 95% and the charging stop backoff is set to 1%, charging resumes when the battery SOC drops below $95\% - 1\% = 94\%$.

Stop(Discharge) : Discharge in the grid-connected state up to the SOC. In the grid-connected state, when the battery is lower than or equal to this value, the battery stops discharging. It is usually used as the standby power SOC.

Stop discharge return difference: Restore the discharge return difference value. When the actual battery SOC+ stop discharge return difference value is higher than the set SOC value, restore the battery discharge. For example, if the stop discharge threshold is set to 50% and the stop discharge return difference is set to 1%, then when the actual battery SOC is higher than $50\% + 1\% = 51\%$, the discharge will be restored.

DG Power Off: used when communicating with the diesel generator through dry contact signal. When SOC is greater than or equal to this setting value, EMS controls the shutdown of the diesel generator.

DG Power On: used when communicating with the diesel generator through dry contact signal. When the SOC is less than or equal to this setting value, EMS controls the startup of the diesel generator.

Off Grid PCS Power off: In off-grid state, when the battery SOC is lower than this value, the inverter will shut down and stop working.

Shut-off point return difference: When the inverter is off, after shutdown, when the PV is up, the battery will be charged. When the battery charge reaches the off-grid shutdown setting SOC+ shutdown point return difference SOC, the inverter will restart.

After setting the parameters, click Save parameters .

3.3.2. Lead-acid battery configuration (only for self-use)

Check the use of battery voltage Use Bat V →  Previous page → Plumbic ,

select lead-acid battery,

Set the charging end voltage, discharge end voltage, constant current value (maximum discharge current), battery capacity (corresponding to the battery capacity)

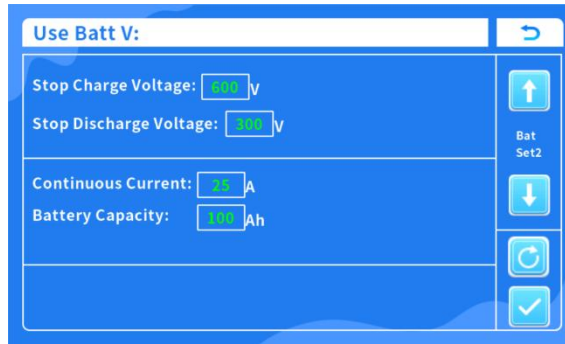



Figure 9 Lead-acid battery configuration

3.4. Work mode configuration

Note: The battery SOC must be set before the mode can be set.

Home screen >  Settings icon in the upper right corner >  System working mode to enter the mode setting page.

The main ones are:

pattern	application scenarios
Self-consumption	Photovoltaic power generation for self-use, not selling electricity to the grid
Grid-connected surplus electricity	The photovoltaic power is used for self-use and the surplus is sold to the grid
time function	Periodic charging and discharging, backup power, peak-valley arbitrage, oil engine charging
Self-use + backup power	For self-use of photovoltaic power generation, the battery needs to be off-grid (power failure)
Meter anti-backflow	The photovoltaic and battery outputs need to be output to the grid port, but not in reverse current to the grid

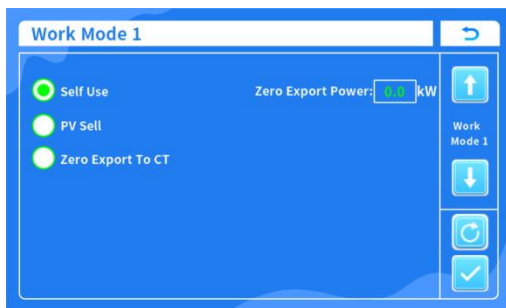

Figure 10 Working mode

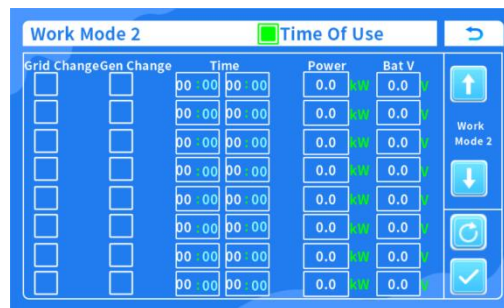





Figure 11 Time function

3.4.1. Set up self-use mode

Mode description: In the self-use mode, the power supply order of the load is: PV > battery > grid. The PV gives priority to the power supply to the load. When the PV is insufficient, the battery supplements. When the PV and battery are insufficient, the grid participates in the power supply.



Setting method:

Home screen →  Settings icon in the upper right corner →  System working mode Enter the mode setting page,  select self-use, and set the anti-flow power to 0kW or-0.1kW (it will continue to draw 0.1kW from the grid, and the anti-flow effect will be better), then click save Settings .

3.4.2. Set the surplus power on the Internet mode

Mode description: In the mode of surplus power on the grid, the priority order of photovoltaic output is: load> battery> grid. When the photovoltaic output is greater than the load and the battery is full, the excess photovoltaic output will be output to the grid.

Setting method:

Home screen> Settings icon in the upper right corner  >  System working mode.  Enter the mode setting page and select "Save power to the Internet".

3. 4. 3. Set the time function

Mode description: The time function setting interface can set the charging and discharging of multiple charging and discharging periods (power discharged to the grid), which can be used for grid charging, peak shaving and valley filling, diesel power charging, etc.

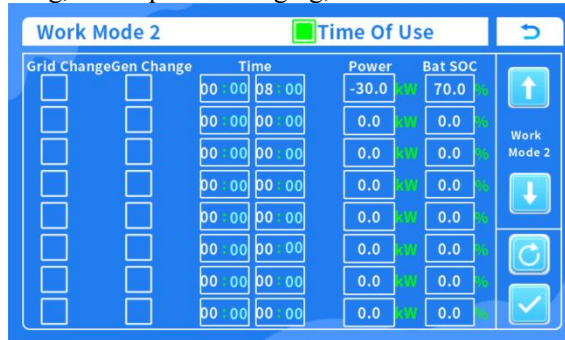



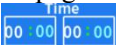



Figure 12 Time function configuration

Setting method:

Home screen → Settings icon  in the upper right corner →  System Work Mode Enter the mode setting page,

Click  to go to the next page.

Setting of charging time : Set the charging and discharging time periods. Multiple charging and discharging time periods can be set. The time periods cannot be repeated or cross days.

Charge/discharged power setting : set the charge/discharged power in the corresponding time period, negative for charging, positive for discharging.

As of Bat SOC setting : the corresponding charge or discharge SOC, which has a lower priority than the battery setting interface. If the actual battery SOC reaches the value set in the battery setting interface, it will be prioritized.

After the setting is completed according to the  requirements,  check the use of the time function and click save the setting.

3. 4. 4. Set the self-use + backup power mode

Mode description: Spontaneous use + backup power mode,
 When the battery SOC is greater than the standby power SOC, the load power supply order is: PV> battery> grid. The PV gives priority to the load power supply. When the PV is greater than the load, the excess part is used for battery charging; when the PV is insufficient, the battery supplements; when the PV and battery give power to the load at the same time, the grid participates in the power supply;
 When the battery SOC is less than the standby power SOC, the power supply order is: photovoltaic> power grid, photovoltaic gives priority to the load power supply, and the excess photovoltaic charges the battery. When the photovoltaic is insufficient, the power grid participates in the power supply, and the battery does not output.

Setting method:

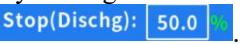
Step 1: Enter the battery SOC setting interface (see 1.2 Battery Settings for details), and set the value of the SOC at which discharge ends (for backup power SOC) .

Step 2: Main interface → Settings icon  in the upper right corner → System working mode . Enter the mode setting page and select self-use .



Step 3 (for grid charging applications): In the time function configuration interface, set the charging duration, power output, and end-of-charge (SOC) threshold for the grid (diesel generator). Typically, the grid's SOC threshold is higher than the battery's. The photovoltaic system will utilize the excess capacity to charge the battery beyond this threshold.

All the setting values can be flexibly set and adjusted according to the actual field requirements.

3.4.5. Set the meter to anti-flow mode

Mode description: It is usually used when part of the load needs to be connected to the power grid port. When using the inverter anti-flow, the default self-use mode is activated. In this case, the anti-flow inverter inside the inverter does not take effect. The PV and battery outputs to the LOAD port (off-grid port) and GRID port (power grid port) will not flow back to the power grid.

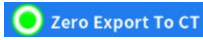
Setting method:

Connect the anti-flow meter to the meter  → Enter the meter and configure the anti-flow meter (see 3.5. How to Configure the Meter for details) → Return to the working mode Settings check the anti-flow meter → Click save Settings .



3.5. Meter configuration

The EMS can be configured with up to two meters of two types: anti-flow meters and metering meters.

Before configuring the meter, confirm the meter wiring. The 485 communication line of the meter should be connected to the RS485 interface of EMS. See the interface description for details.

Connected meter models: Ankerui ADL400, Ankerui DTSD1352.

Setting method:

Home screen> Settings  icon in the upper right  corner> Advanced functions  > Meter configuration.

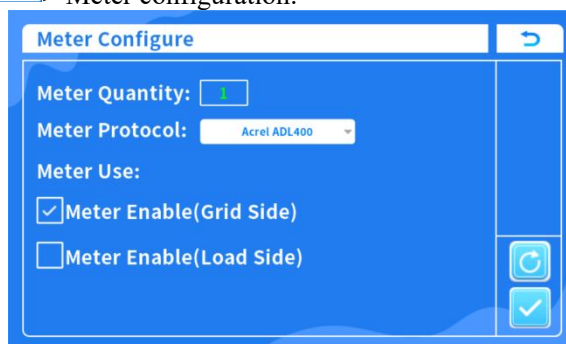
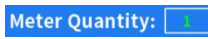



Figure 13 Meter configuration

Select the number  of meters →  Select the meter protocol → Check the meter enable (depending on where the meter is connected, either  at the grid end or at the load end, with anti-reverse current meters usually connected at the grid end) → Click save Settings

remarks :

- 1) When the meter is connected to the grid side, the 485 communication address of the meter should be set as 150; when the meter is connected to the load side, the 485 communication address of the meter should be set as 151.
- 2) The communication baud rate of the electricity meter should be set to 9600.

3.6. Automatic activation of diesel generator configuration

To automatically start the diesel generator, two 485 communication lines need to be drawn from any DO port pin of EMS and connected to the NO relay of the diesel generator.

The diagram is as follows:

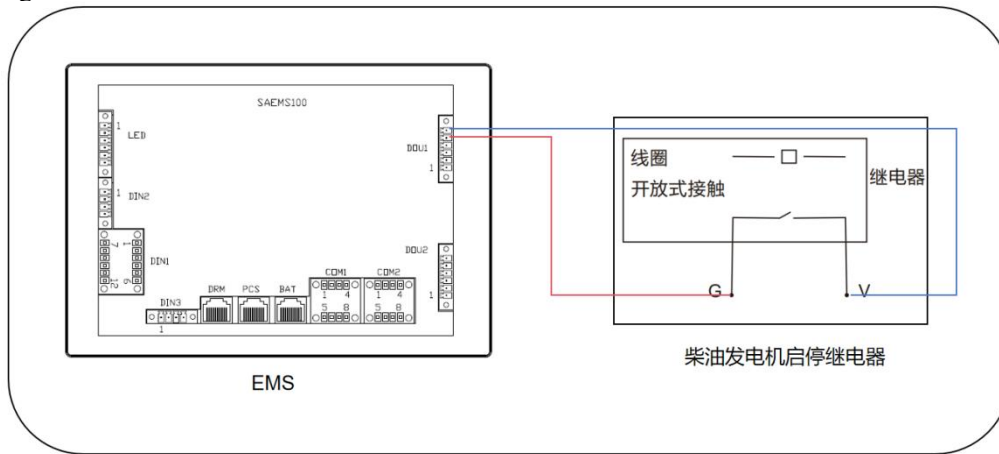





Figure 14 Diesel generator wiring

After connecting the communication line, configure it on the local MES.

Step 1:

Home screen → Settings icon  in the upper right corner → Advanced functions  →  I/o config →  Next page to output configuration page

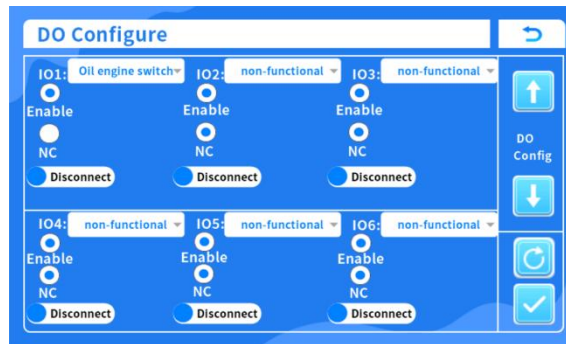





Figure 15 Generator start/stop dry contact configuration

Select the dry contact configuration option corresponding to the wiring , select the oil engine switch  and click enable, If the wiring is normally closed, check NC ; if it is normally open, uncheck it.

Step 2:



Home screen →  Settings icon in the upper right corner → Battery Settings →  Next page → Enter the battery SOC setting interface → Set the “DG Use” switch on/off based on SOC
Note: “Power On SOC” is the threshold for starting the engine, and “Power Off SOC” is the threshold for shutting down the engine./e.



Figure 16 Generator SOC start/stop configuration

3.7. Weak grid configuration

Grid configurations are typically deployed in low-voltage grid areas and diesel generator systems where grid frequency and voltage conditions are suboptimal. These solutions can be customized by adjusting the inverter's parameters—including under-voltage detection thresholds, over-voltage thresholds, under-frequency thresholds, over-frequency thresholds, and response time intervals—to effectively adapt to challenging grid environments.

Home screen →  Settings icon in the upper right corner → Power grid Settings → Enter the power grid Settings interface

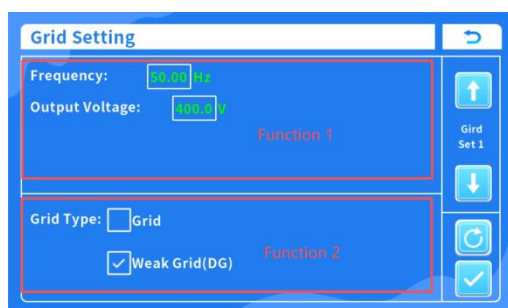

Figure 17 Power grid Settings Page 1

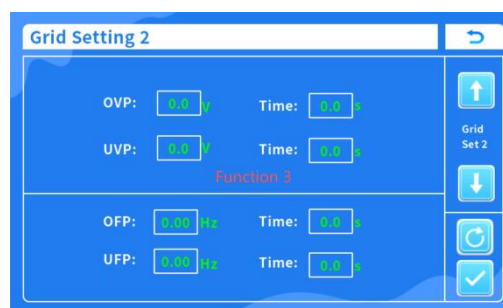

Figure 18 Power grid Settings Page 2

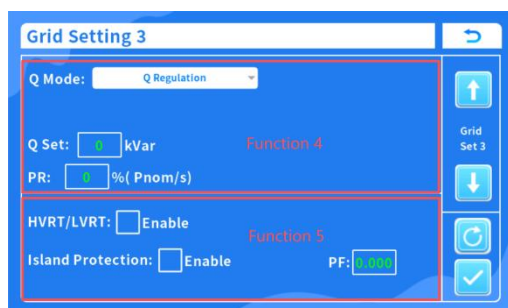

Figure 19 Power grid Settings page 3

Function 1: Set the power grid frequency and output voltage.

Function 2: Select the power grid type. Check Grid the ordinary power grid, and check the “Weak Grid(DG)” Weak Grid(DG) when the frequency or voltage of the power grid (oil engine) is poor, which will expand the range of voltage and frequency judgment to be compatible with the weak power grid scenario.

Function 3: manually adjust voltage, frequency range and time judgment.

Function 4: reactive power regulation.

Function 5: voltage traversal, island detection setting, power factor adjustment.





3.8. Multi-machine parallel configuration

Multi-machine parallel operation is divided into three cases

1) A single EMS connects to multiple inverters, as shown in the following schematic diagram:



graph 20

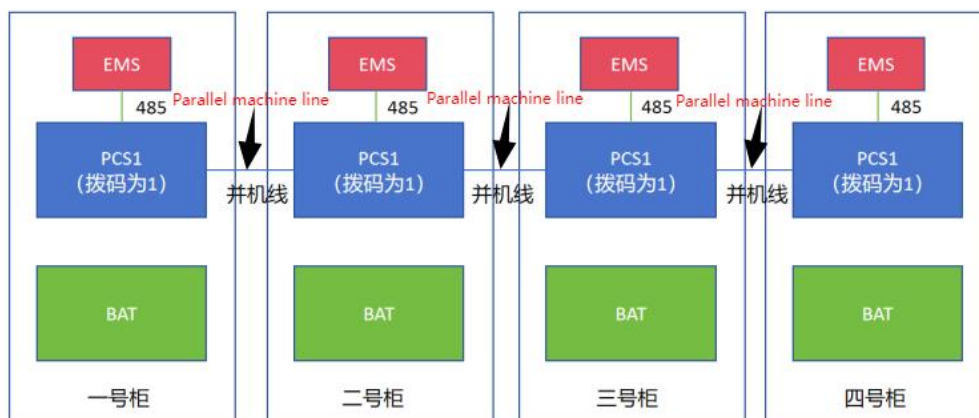

Local EMS screen setting method: Main interface →  Settings icon in the upper right corner to enter the Settings interface → Administrator functions  → Converter/system configuration  → Set the number of converters  → Click save parameters .

2): A single system is an EMS connected to a single PCS, and multiple systems are connected in parallel, as shown in the following schematic diagram:



graph 21

Local EMS screen setting method:

Home screen →  Settings icon in the upper right corner → Administrator functions 

→ Next page  → Enter the cabinet Settings page.

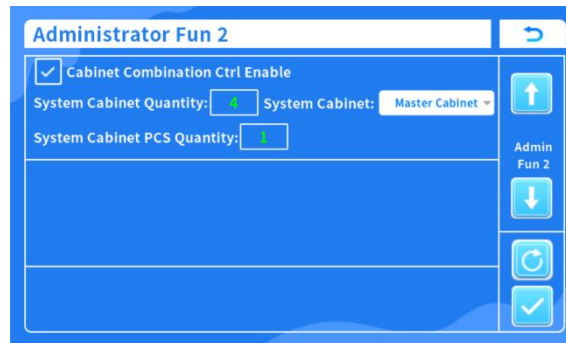



graph 22

Check the cabinet Combination Ctrl Enable Cabinet Combination Ctrl Enable, Set the System Cabinet Quantity according to the actual number of parallel units. Each EMS selects the number of system cabinets according to the master-slave relationship of the system cabinet .

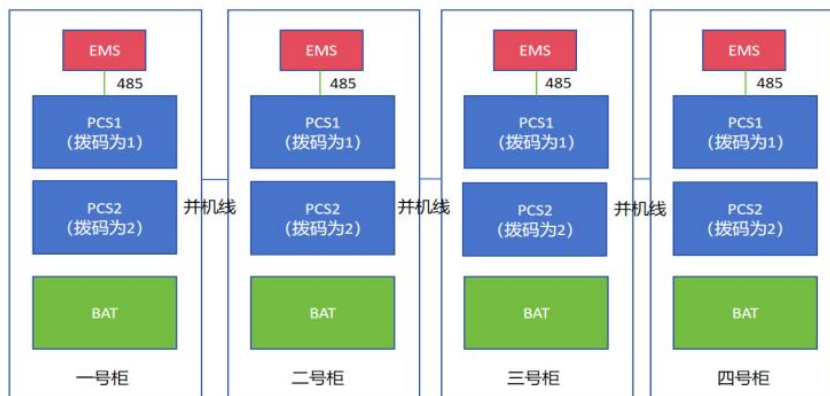
3): A single system is an EMS connected to multiple inverters, and multiple systems are connected in parallel, as shown in the following schematic diagram:



graph 23

Home screen →  Settings icon in the upper right corner → Administrator functions 

→ Next page  → Enter the cabinet Settings page.

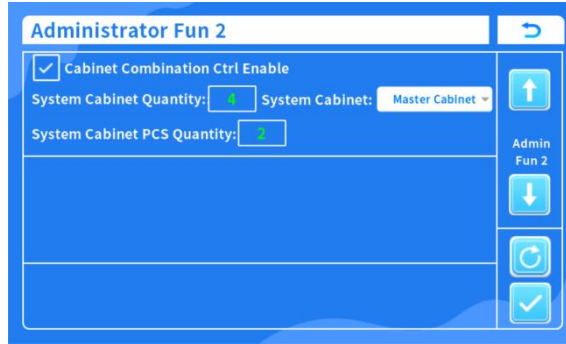

graph 24

Check the parallel cabinet enablement Cabinet Combination Ctrl Enable , set the number of parallel cabinets , set the number of converters in a single system cabinet , and select the number of system cabinet numbers according to the master-slave relationship of the system cabinet for each EMS .

3.9. Air conditioning information and configuration

Communicate with the air conditioner, set the air conditioner parameters, check the air conditioner communication wiring, and then perform the following operations after confirmation:

Home screen → Settings icon in the upper right corner → Advanced functions

→ Air conditioning Settings → Enter the air conditioning Settings page.





Figure 25 Air conditioning configuration

Set the number of air conditioners, select the air conditioner protocol, and click save parameters .

3.10. PCS emergency stop configuration

PCS DIN: X1 access to the emergency stop button is used. The emergency stop is normally closed by default. If you need to open it, you need to set it:

Home screen >  Settings icon in the upper right corner > [Advanced Function 2](#) > Advanced Function 2 > "Epo Logic:NC"  > Click Save parameters .

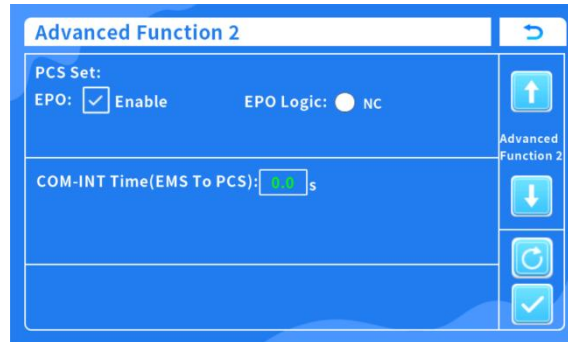

Figure 26 PCS emergency stop configuration

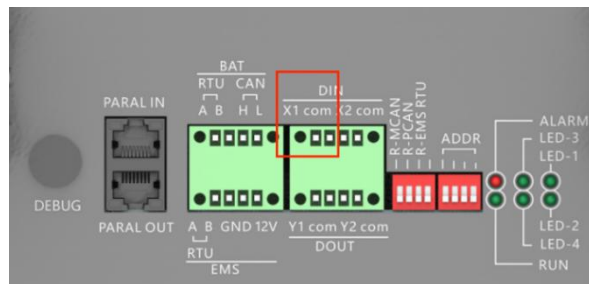

Figure 27 PCS emergency stop terminal

3.11. Charging module configuration

When connected to the charging module, the maximum charging current and voltage can be set.

Home screen →  Settings icon in the upper right corner → [Advanced Function](#) > Advanced function

→ Page turn → Find charging module Settings interface

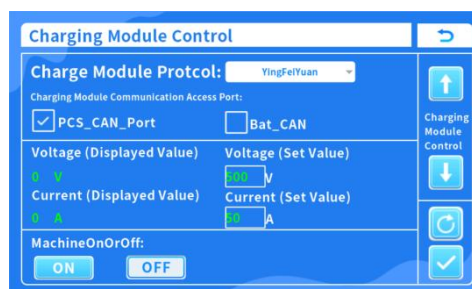



Figure 28 Charging module configuration

Select communication protocol→select the access communication port→set the voltage regulator
 →set the maximum current→switch on/off. The automatic switch on/off of the charging module is determined and adjusted according to the SOC of the starting and stopping of the diesel generator.

3.12. Single-phase charging function configuration

The single-phase charging function is only available when charging is connected to the grid, and only supports A-phase access and A-phase load.

Operation instructions: Main interface→ Settings icon in the upper right corner to enter the

Settings interface→Advanced function  →Page turn  →Find the single-phase charging

Settings interface→Check the single-phase charging mode→ Set the charging power.

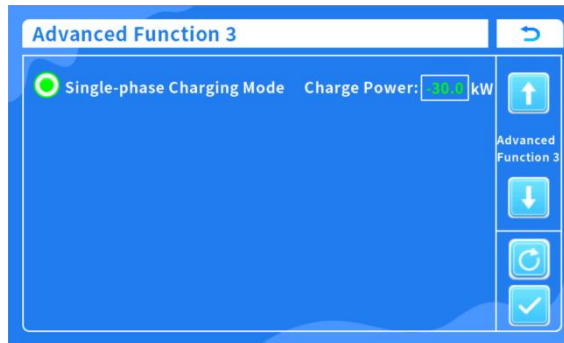

Figure 29 Single-phase charging configuration

3.13. Dry contact configuration

3.13.1. Indicator light configuration

characteristic		function	Optional items	remarks	
LED	J1	Alarm indicator	The default alarm indicator cannot be configured	PCS alarm, BMS alarm, and low SOC (SOC below PCS shutdown threshold).	
	J2				
	J3	Running indicator light	The default operation indicator cannot be	Chang Liang	And offline, PCS is on and running
				1S flashing	PCS await the opportune

			configured		moment
	J4			3S always on, 100MS flashing	Off the grid, PCS is up and running
	J5	fault indicating lamp	Default fault indicator, not configurable	PCS faults, emergency stops, faults caused by input dry contacts, BMS protection and faults.	
	J6				

3. 13. 2. EMS emergency stop, switch on/off configuration

characteristic		function	Optional items	remarks
DIN2	J1	EPO	The default emergency stop function cannot be configured	1、 By default, it is a normally open dry contact. If the dry contact is connected to a normally closed dry contact, the logic of the emergency stop function should be reversed. 2、 When the normally closed signal is input, the EPO function is triggered, the EMS generates corresponding alarms, and the PCS is forced to shut down.
	J2			
	J3	PCS Startup & Shutdown	The default PCS power on/off function cannot be configured	1、 By default, it is a normally open dry contact. If the dry contact is connected to a normally closed dry contact, the logic of the emergency stop function should be reversed. 2. Input a normally closed signal to force the PCS to start up, and input a normally open signal to force the PCS to shut down.
	J4			

3. 13. 3. Enter DI custom configuration

Operation instructions: Main interface →  Settings icon in the upper right corner to enter the Settings interface → Advanced functions → Input and output configuration

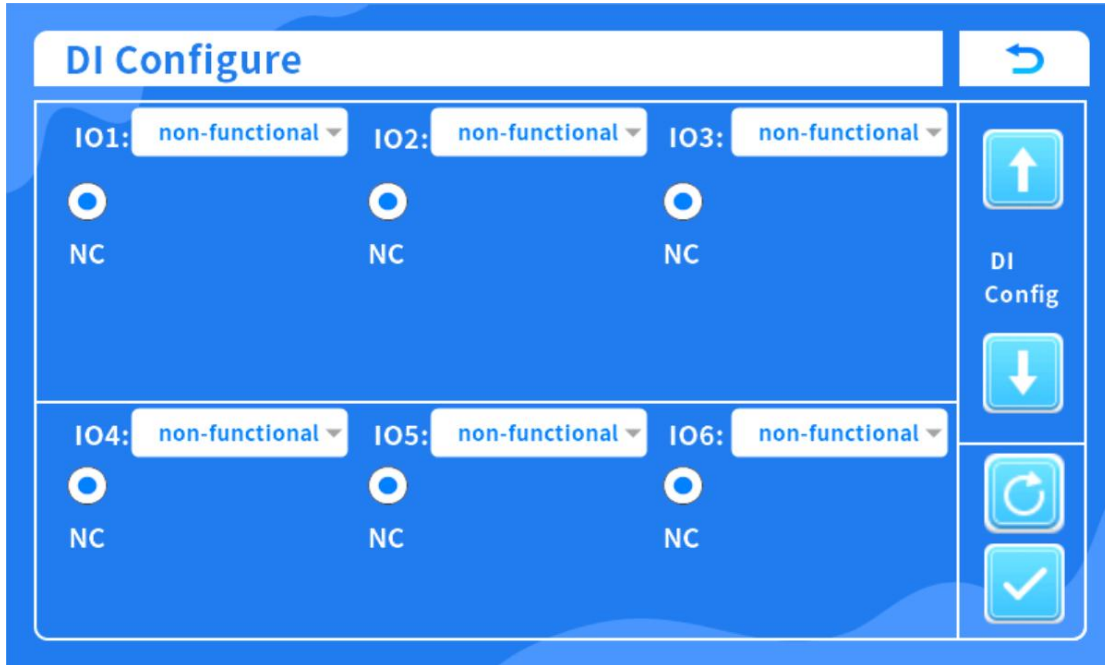



Figure 30 Input dry contact configuration page

Port identifier		EMS interface	Optional items	function	remarks
DIN 1	J1	Input 6 (DI6)	Default is not functional, can be configured	1. It is assumed to be a normally open dry contact. If the dry contact is connected as a normally closed dry contact, the normally closed button should be enabled. 2. Customizable configuration options include: alarm systems, fault detection, cabinet door alerts, ATS feedback, contactor feedback, generator feedback, fire alarms, fire emergency alerts, smoke detectors, water intrusion sensors,	Default enabled
	J2				Default enabled
	J3	Input 5 (DI5)	Default is not functional, can be configured		Default enabled
	J4				Default enabled
	J5	Input 4 (DI4)	Default is not functional, can be configured		Default enabled
	J6				Default enabled
	J7	Input 3 (DI3)	Default is not functional, can be configured		Default enabled
	J8				Default enabled
	J9	Input 2 (DI2)	Default is not functional, can be configured		Default enabled
	J10				Default enabled
	J11	Input 1	Default is not		Default

	J12	(DI1)	functional, can be configured	shutdown (input), startup (input), emergency stop (input), lightning protection alarms, off-grid operation control, molded case circuit breakers (input), and molded case circuit breakers (output). 3. If you need other functions, please contact the manufacturer for customization;	enabled
--	-----	-------	-------------------------------	--	---------

remarks :

1) After setting the parameters, you need to click "Issue Settings" and click "Yes"

 to confirm the successful delivery of parameters .

2) Do not set the same function for different IO ports.

3. 13. 4. Custom output DO configuration

Operation instructions: Main interface →  Settings icon in the upper right corner to enter the Settings interface → Advanced functions → Input and output configuration

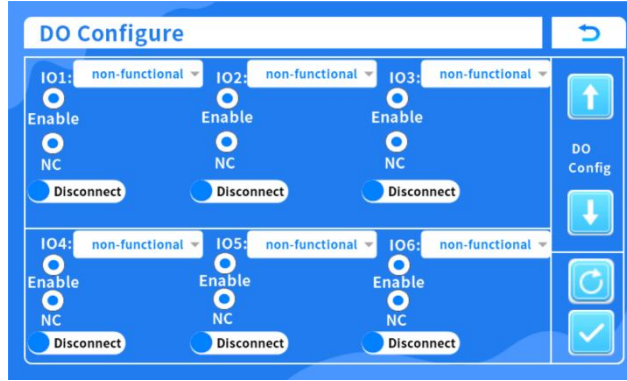



Figure 31 Output dry contact configuration page

Port identifier		EMS interface	Optional items	function	remarks
DOU1	J1	output 3 (DO3)	Default is not functional, can be configured	1. It is assumed to be a normally open dry contact. If the dry contact is connected as a normally closed dry contact, the normally closed button should be enabled. 2. Customizable configuration options include: generator switch, grid-connected/off-grid switching, fan control, relay control, contactor control, AC trip control, cell-specific fan control, single-load start-stop control, heater control (cell temperature monitoring), electrical operation control (opening/closing),	Disabled by default, if you want to enable it, please check enabled;
	J2				
	J3	output 2 (DO2)	Default is not functional and can be configured		Disabled by default. If enabled, please check enabled;
	J4				
	J5	output 1 (DO1)	Default oil engine start/stop control can be configured		Disabled by default. If enabled, check it.
	J6				
DOU 2	J7	output 6 (DO6)	Default is not functional, can be configured	temperature monitoring), electrical operation control (opening/closing),	Disabled by default. If enabled, please check enabled;
	J8				
	J9	output 5 (DO5)	Default is not functional, can be configured		Disabled by default. If enabled, please check
	J10				

	J11			liquid cooling fluid replenishment control, DC trip control (cell voltage monitoring), and DC trip control (fault detection). 3. If other functions are needed, please contact the manufacturer for customization;	enabled;
	J12	output 4 (DO4)	Default is not functional, can be configured		Disabled by default. If enabled, please check enabled;

remarks :

- 1) After setting the parameters,  you need to click  "Issue Settings" and click "Yes" to confirm that the parameters have been issued successfully.
- 2) Do not set the same function for different IO ports.

3.14. Other display interface description

Click the grid, load, PCS, PV and battery icons on the home page to enter the detailed information view interface.

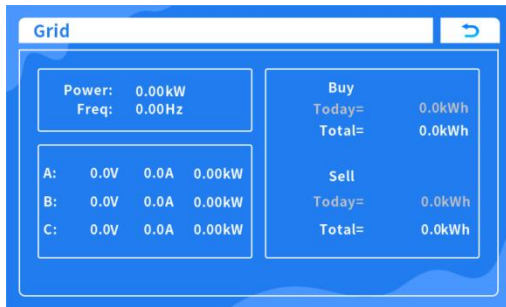

Figure 32 Grid details page Figure

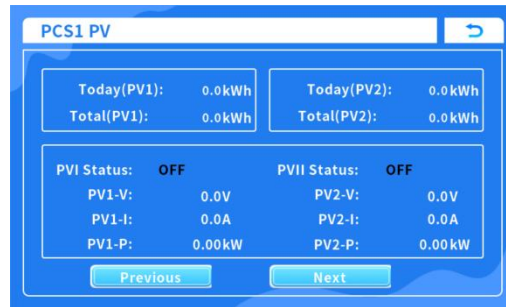

Figure 33 PV details page



Figure 34 Load details page Figure



Figure 35 Battery cluster details page

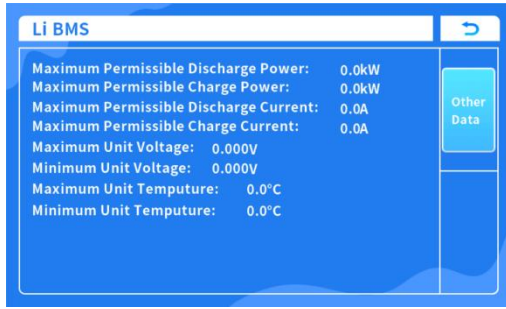

Figure 36 Battery cluster detail page 2

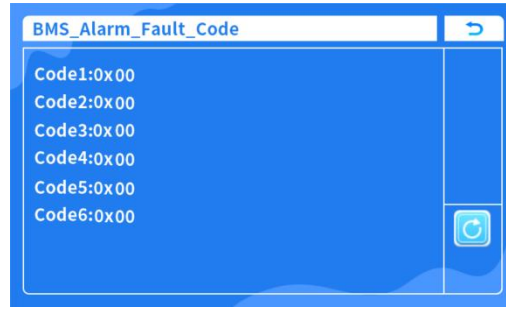



Figure 37 Battery cluster detail page 3

3.15. Check for faults and troubleshoot

3.15.1. Check for system failures

Home screen → Exclamation  mark in the upper left  corner → Enter the fault information view screen. Click to clear the historical fault and only display the current fault information.

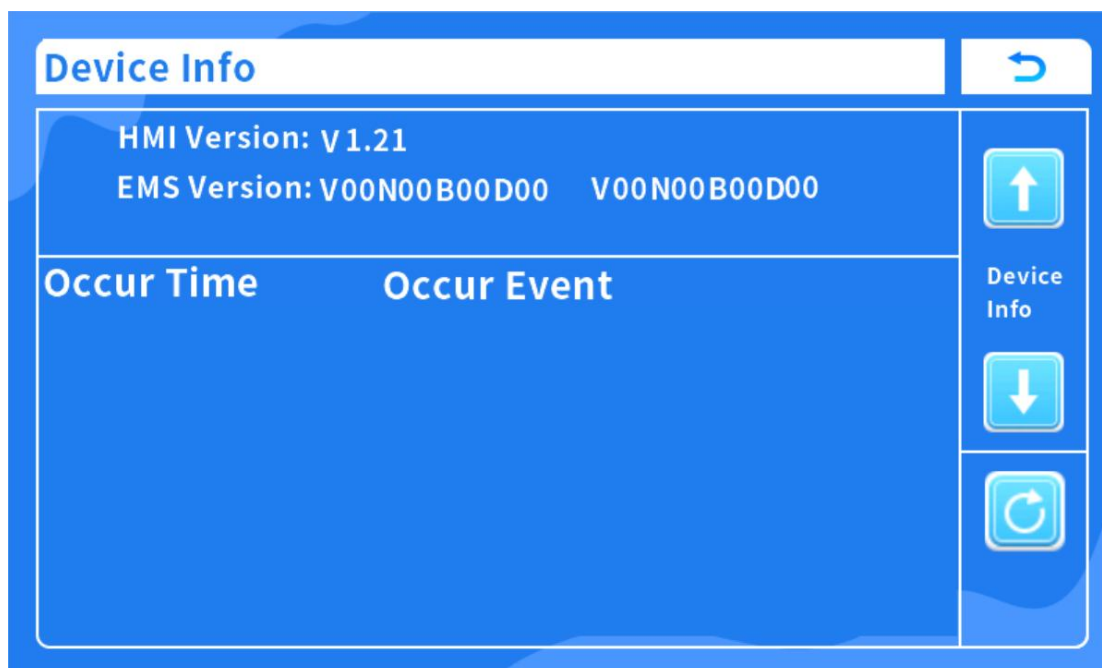

Figure 38 Equipment information

3.15.2. Refer to the table for fault information

Alarm or fault name	fault code	Whether to turn off	Method of fault recovery	Measures to eliminate the fault
jerk	F115	shut down	Restore manually after manual site inspection	1. Check whether the emergency stop function is triggered; 2. Check whether the EMS dry contact is set in reverse; 3. After the above operation, if the fault still exists, contact the manufacturer for treatment
Fire alarm	F104	shut down	Restore manually after manual site inspection	1. Check whether there is a fire on the site; 2. Whether the dry contact of EMS is reversed; 3. After the above operation, if the fault

				still exists, contact the manufacturer for treatment;
Fire alarm	F103	shut down	Restore manually after manual site inspection	1. Check whether there is a fire on the site; 2. Whether the dry contact of EMS is reversed; 3. After the above operation, if the fault still exists, contact the manufacturer for treatment;
Lightning protection alerts	F107	shut down	Restore manually after manual site inspection	1. Check whether the field equipment is struck by lightning; 2. Whether the dry contact of EMS is reversed; 3. After the above operation, if the fault still exists, contact the manufacturer for treatment;
Smoke alarms	F105	shut down	Restore manually after manual site inspection	1. Check whether there is a fire on the site; 2. Whether the dry contact of EMS is reversed; 3. After the above operation, if the fault still exists, contact the manufacturer for treatment;
Cabinet door alarm	F99	Don't turn off the computer	Self-recovery	1. Check whether the door is open; 2. Whether the dry contact of EMS is reversed; 3. After the above operation, if the fault still exists, contact the manufacturer for treatment;
Inverter faults	F1	shut down	Self-recovery	1. The module is powered down and waits for 1-2 minutes before the module restarts; 2. After the above operation, if the fault still exists, please contact the manufacturer for treatment;
N line abnormality	F2	shut down	Self-recovery	1. The module is powered down and waits for 1~2 minutes before the module restarts; 2. After the above operation, if the fault still exists, please contact the

				manufacturer for treatment;
Synchronous signal fault	F4	shut down	Self-recovery	1. Check whether the network cable between the two machines is connected properly; 2. Replace the network cable;
Relay failure	F5	shut down	Restore power	1. Power off the module, check whether the AC side relay is damaged or adhered; 2. After the above operation, if the fault still exists, please contact the manufacturer for treatment;
Circuit breaker current limiting	F6	shut down	Self-recovery	1. The module is powered down and waits for 1-2 minutes before restarting; 2. After the above operation, if the fault still exists, please contact the manufacturer for treatment;
The reverse transformer softens and fails	F7	shut down	Self-recovery	1. The module is powered down and waits for 1-2 minutes before the module restarts; 2. After the above operation, if the fault still exists, please contact the manufacturer for treatment;
AC short trouble	F8	shut down	Self-recovery	1. Check whether there is a short circuit between phases;
AC side overload protection	F9	shut down	Self-recovery	1. If the load is overloaded for a long time, check the load;
AC three-phase unbalanced overload protection	F10	shut down	Self-recovery	1. Check whether the load of each phase is too unbalanced;
Low off-grid output voltage	F11	shut down	Self-recovery	1. Check the load type; 2. Contact the manufacturer for treatment;
High off-grid frequency	F12	shut down	Self-recovery	1. Check the load type; 2. Contact the manufacturer for treatment;

Low off-grid frequency	F13	shut down	Self-recovery	1. Check the load type; 2. Contact the manufacturer for treatment;
Overload alarm is in progress	F14	Only alarm, not shutdown	Self-recovery	1. Check whether the load is too large;
Trip current limit alarm	F15	Only alarm, not shutdown	Self-recovery	1. Check whether the load is too large;
Machine quota limit sign	F16	Only alarm, not shutdown	Self-recovery	1. Check the PCS temperature; 2. Check whether the load is too large;
Mother line imbalance	F17	shut down	Self-recovery	1. Power down the module, wait 1-2 minutes, and restart the module; 2. After the above operation, if the fault still exists, please contact the manufacturer for treatment;
Bus overvoltage	F18	shut down	Self-recovery	1. Power down the module, wait 1-2 minutes, and restart the module; 2. After the above operation, if the fault still exists, please contact the manufacturer for treatment;
Under-voltage at the bus	F19	shut down	Self-recovery	1. Power down the module, wait 1-2 minutes, and restart the module; 2. After the above operation, if the fault still exists, please contact the manufacturer for treatment;
Motherboard hardware exception	F20	shut down	Self-recovery	1. Power down the module, wait 1-2 minutes, and restart the module; 2. After the above operation, if the fault still exists, please contact the manufacturer for treatment;
Bus capacitor soft start process	F21	shut down	Self-recovery	1. Power down the module, wait 1-2 minutes, and restart the module; 2. After the above operation, if the fault still exists, please contact the manufacturer for treatment;
DC input reversed	F22	shut down	Self-recovery	1. Check whether the positive and negative of DC input are reversed;

DC input overvoltage	F23	shut down	Self-recovery	<p>1. Check whether the DC input voltage is overvoltage;</p> <p>2. Power off and wait for 1 minute, then power on again;</p>
DC input under-voltage	F24	shut down	Self-recovery	<p>1. Check whether the DC input voltage is undervoltage;</p>
DC1 overcurrent	F25	shut down	Self-recovery	<p>1. Check whether the discharge is excessive;</p>
DC2 overcurrent	F26	shut down	Self-recovery	<p>1. Check whether the current is too high during charging;</p>
DC hardware overcurrent	F27	shut down	Self-recovery	<p>1. Check whether the load is too large;</p>
PV hardware overcurrent	F28	Only PV is closed	Self-recovery	<p>1. The module is powered down and waits for 1~2 minutes before the module restarts;</p> <p>2. After the above operation, if the fault still exists, please contact the manufacturer for treatment;</p>
Unbalanced overcurrent	F29	shut down	Self-recovery	<p>1. The module is powered down and waits for 1-2 minutes before the module restarts;</p> <p>2. After the above operation, if the fault still exists, please contact the manufacturer for treatment;</p>
IGBT overheating	F30	shut down	Self-recovery	<p>1. The module is powered down and waits for 1-2 minutes before the module restarts;</p> <p>2. After the above operation, if the fault still exists, please contact the manufacturer for treatment;</p>
DC current imbalance	F31	shut down	Self-recovery	<p>1. The module is powered down and waits for 1-2 minutes before the module restarts;</p> <p>2. After the above operation, if the fault still exists, please contact the manufacturer for treatment;</p>

DC contactor fault	F32	shut down	Restore power	<p>1. The module is powered down and waits for 1-2 minutes before the module restarts;</p> <p>2. After the above operation, if the fault still exists, please contact the manufacturer for treatment;</p>
Low power grid frequency	F33	shut down	Self-recovery	<p>1. Check whether the low frequency protection point of the power grid is set too high</p> <p>2. Check whether the time of low frequency protection point of the power grid is too short;</p>
High power grid frequency	F34	shut down	Self-recovery	<p>1. Check whether the high frequency protection point of the power grid is set too low</p> <p>2. Check whether the time of high frequency protection point of the power grid is too short;</p>
Low grid voltage	F35	shut down	Self-recovery	<p>1. Check whether the low voltage protection point is set too low</p> <p>2. Check whether the time of low-voltage protection point of the power grid is too short;</p>
High grid voltage	F36	shut down	Self-recovery	<p>1. Check whether the high voltage protection point of the power grid is set too low</p> <p>2. Check whether the time of high voltage protection point on the power grid is too short;</p>
Grid reversal	F37	shut down	Self-recovery	<p>1. Check whether the PCS AC input wiring is reversed;</p>
Island malfunction	F40	shut down	Self-recovery	<p>1. The module is powered down and waits for 1-2 minutes before the module restarts;</p> <p>2. After the above operation, if the fault still exists, please contact the manufacturer for treatment;</p>

Current overcurrent	F41	shut down	Self-recovery	<p>1. The module is powered down and waits for 1-2 minutes before the module restarts;</p> <p>2. After the above operation, if the fault still exists, please contact the manufacturer for treatment;</p>
N line current overcurrent	F42	shut down	Self-recovery	<p>1. The module is powered down and waits for 1-2 minutes before the module restarts;</p> <p>2. After the above operation, if the fault still exists, please contact the manufacturer for treatment;</p>
Inductive current overcurrent	F43	shut down	Self-recovery	<p>1. The module is powered down and waits for 1-2 minutes before the module restarts;</p> <p>2. After the above operation, if the fault still exists, please contact the manufacturer for treatment;</p>
Low voltage traversal fault	F44	shut down	Self-recovery	<p>1. The module is powered down and waits for 1-2 minutes before the module restarts;</p> <p>2. After the above operation, if the fault still exists, please contact the manufacturer for treatment;</p>
High voltage traversal fault	F45	shut down	Self-recovery	<p>1. The module is powered down and waits for 1-2 minutes before the module restarts;</p> <p>2. After the above operation, if the fault still exists, please contact the manufacturer for treatment;</p>
Leakage current alarm	F47	Only alarm, not shutdown	Self-recovery	<p>1. Check whether the leakage current protection point is set too low;</p> <p>2. Check whether the time of leakage current protection point is too short;</p>
Lightning protection faults	F49	shut down	Self-recovery	<p>1. Check whether it is struck by lightning;</p>
Fan alarms	F50	shut down	Self-recovery	<p>1. Check whether the fan is damaged;</p>
insulation fault	F51	Only alarm, not	Self-recovery	<p>1. The module is powered down and waits for 1-2 minutes before the module</p>

		shutdown		restarts; 2. After the above operation, if the fault still exists, please contact the manufacturer for treatment;
Model error	F52	shut down	Self-recovery	1. In PCSVF mode, check whether there is voltage on the AC test;
Auxiliary power supply failure	F53	shut down	Self-recovery	1. Check whether the auxiliary power supply voltage is too low; 2. After the above operation, if the fault still exists, please contact the manufacturer for treatment;
COM communication board failure	F55	shut down	Self-recovery	1. The module is powered down and waits for 1~2 minutes before the module restarts; 2. After the above operation, if the fault still exists, please contact the manufacturer for treatment;
BMS out-of-order	F56	shut down	Self-recovery	1. Check for faults on the battery side
Module overheating	F57	shut down	Self-recovery	1. The module is powered down and waits for 1-2 minutes before the module restarts; 2. After the above operation, if the fault still exists, please contact the manufacturer;
IGBT temperature anomaly	F58	shut down	Self-recovery	1. The module is powered down and waits for 1-2 minutes before the module restarts; 2. After the above operation, if the fault still exists, please contact the manufacturer for treatment;
External FLASH exception	F59	shut down	Self-recovery	1. The module is powered down and waits for 1~2 minutes before the module restarts; 2. After the above operation, if the fault still exists, please contact the manufacturer for treatment;

BMS communication alarms	F60	shut down	Self-recovery	1. Check the communication line between PCS and BMS; 2. Check whether the protocol selection of PCS is consistent with BMS;
Internal communication failure	F61	shut down	Self-recovery	1. Check whether the DSP and ARM are wired; 2. Whether DSP or ARM has no program;
MCAN unusual	F62	shut down	Self-recovery	1. Contact the manufacturer for treatment;
PCAN unusual	F63	shut down	Self-recovery	1. Contact the manufacturer for treatment;
PV 1 low voltage	F65	Only PV is closed	Self-recovery	1. Check whether the input voltage of PV 1 is below the input voltage range
Low voltage photovoltaic 2	F66	Only PV is closed	Self-recovery	1. Check whether the pv2 input voltage is below the input voltage range
PV 1 high voltage	F67	Only PV is closed	Self-recovery	1. Check whether the input voltage of PV 1 is higher than the input voltage range
PV 2 high voltage	F68	Only PV is closed	Self-recovery	1. Check whether the pv2 input voltage is higher than the input voltage range
Photovoltaic 1 input reverse	F69	Only PV is closed	Self-recovery	1. Check whether the positive and negative of photovoltaic input 1 are connected in reverse;
Photovoltaic 2 input reverse	F70	Only PV is closed	Self-recovery	1. Check whether the positive and negative of photovoltaic input 2 are connected in reverse;
PV1 overcurrent	F71	Only PV is closed	Self-recovery	1. Check whether PV current is overcurrent;
PV2 overcurrent	F72	Only PV is closed	Self-recovery	1. Check whether PV current is overcurrent;
Low frequency fault on the grid (or oil engine) side	F81	shut down	Self-recovery	1. Check whether the low frequency protection point is set too high 2. Check whether the time of bypassing low frequency protection point is too short;
High frequency on the grid (or oil engine) side	F82	shut down	Self-recovery	1. Check whether the high frequency protection point is set too low 2. Check whether the bypass high

				frequency protection point time is too short;
Low voltage on the grid (or oil engine) side	F83	shut down	Self-recovery	1. Check whether the bypass low voltage protection point is set too low 2. Check whether the bypass low-voltage protection point time is too short;
High voltage on the grid (or oil engine) side	F84	shut down	Self-recovery	1. Check whether the bypass high voltage protection point is set too low 2. Check whether the bypass high voltage protection point time is too short;
Grid (or oil engine) out of order	F87	shut down	Self-recovery	1. Check whether the phase sequence of the bypass is reversed;
Quick test fault of power grid (or oil engine)	F95	shut down	Self-recovery	1. Check the grid side wiring; 2. Contact the manufacturer for treatment;

II. Cloud Platform Configuration and Description

To connect to the cloud platform, you first need to establish a communication connection. The platform is available on both PC (web) and mobile devices. The web version can be accessed at: <https://www.valueclouds.com/#/system/upgradeManagement>, while the mobile app requires downloading.



IOS APP



Android APP

1. 4G/Wifi communication stick

1.1. product appearance

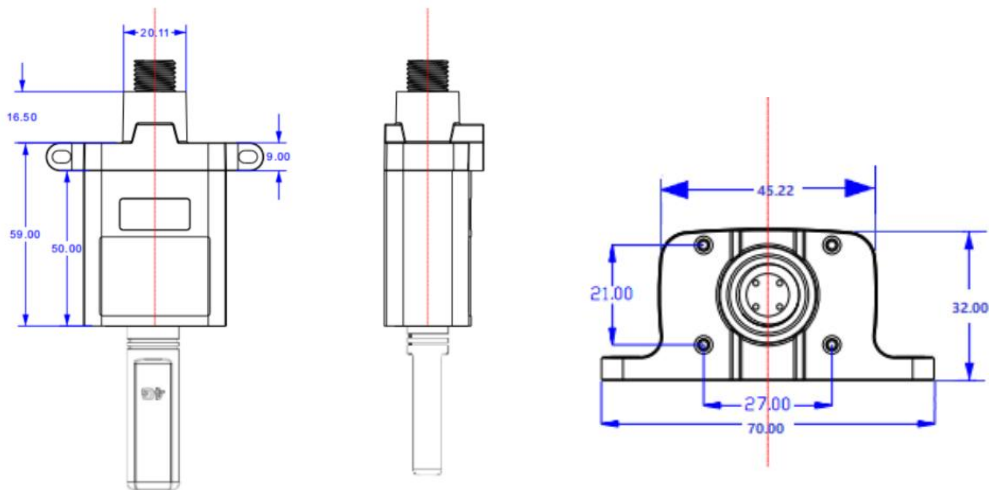

unit : mm

Figure 39 Product appearance dimensions

1.2. Product interface



Figure 40 Product interface

4G/Wifi module aviation plug interface definition

order number	Pin definitions	description
1	GND	Powering up
2	VCC	Input DC voltage DC5V-DC12V
3	RS485-A	RS485 interface A/+
4	RS485-B	RS485 interface B/-



Figure 41 Indicator lights

4G/Wifi module indicator light

order number	Silk screen name	description
1	PWR/ source	Light the lamp: External power input
2	COM/ equipment	Light up the lights: The subordinate equipment responds
3	NET/ networking	Light the lamp: Connect to the base station
4	SRV/连云	Light the lamp: Connect to the specified server

2. Mobile (APP) cloud platform

2.1. Step 1: Register and log in to the APP

Please use your mobile phone to scan the Android QR code.



IOS APP



Android APP

Open the mobile APP, log in your account, if you don't have an account, please register an account first. Note that the PC and mobile account and password are common.

Register a cloud platform account → Log in the account → Log in to the cloud platform

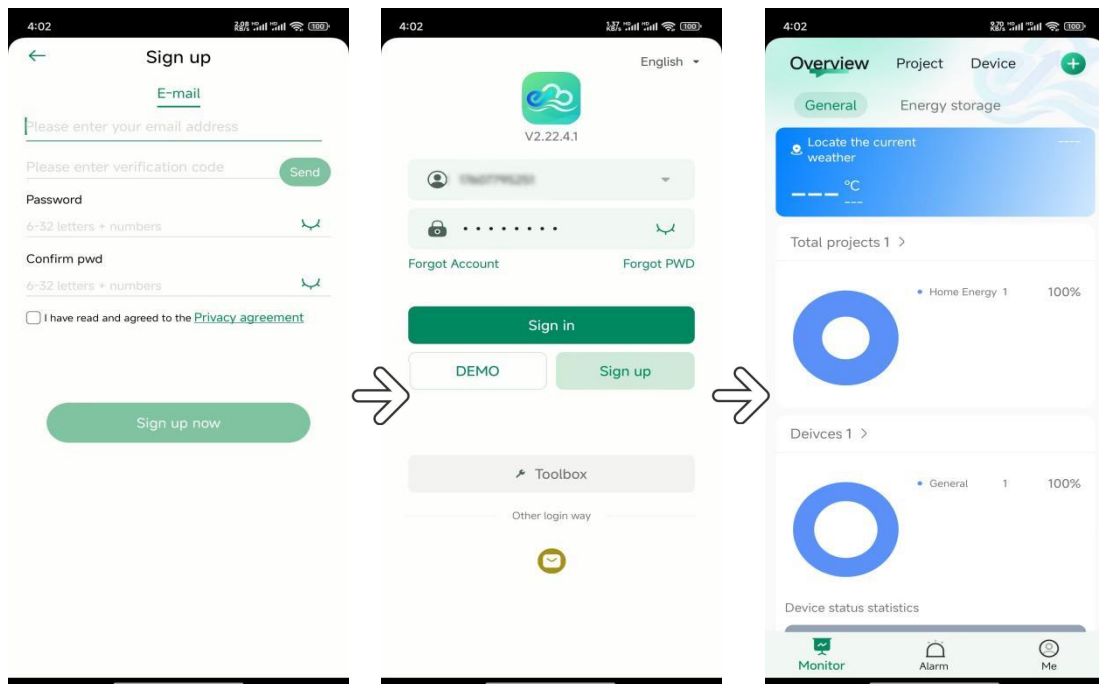

2.2. Step 2: Connect the Wifi stick to the network

The 4G version of the communication stick is plug and play, while the Wifi version of the communication stick requires Bluetooth networking. The following are the steps of the Wifi version of the communication stick to Bluetooth networking.

Note: The Wi-Fi version of the communication stick cannot connect to 5G Wi-Fi. If you are using a Wi-Fi communication stick without 4G Wi-Fi, you can turn on the 4G hotspot on your phone and connect the Wi-Fi module to the phone's hotspot.

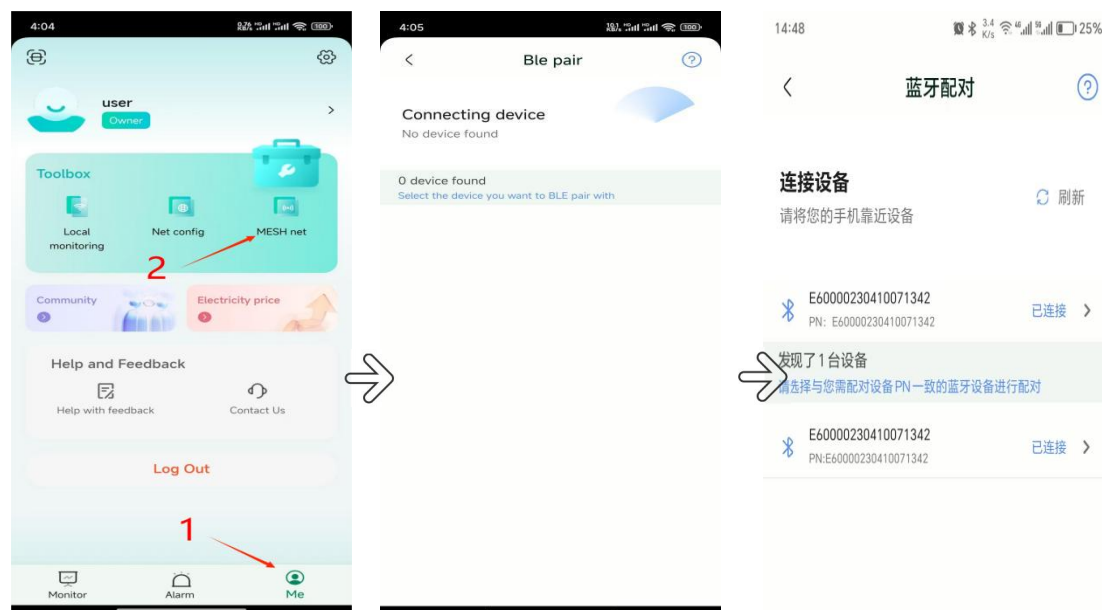

APP My → Click network configuration → Select Bluetooth network → Select the corresponding WiFi communication bar → Connect.

2.3. Add 4G/WiFi communication stick devices to the mobile terminal (APP terminal)

2.3.1. Add a WiFi version of the communication stick

The steps to add a Wifi version communication device are as follows. If the device is added for the first time, configure the network for the device according to Section 6.2.2. After the network is configured, the device will be automatically added to the current login account.

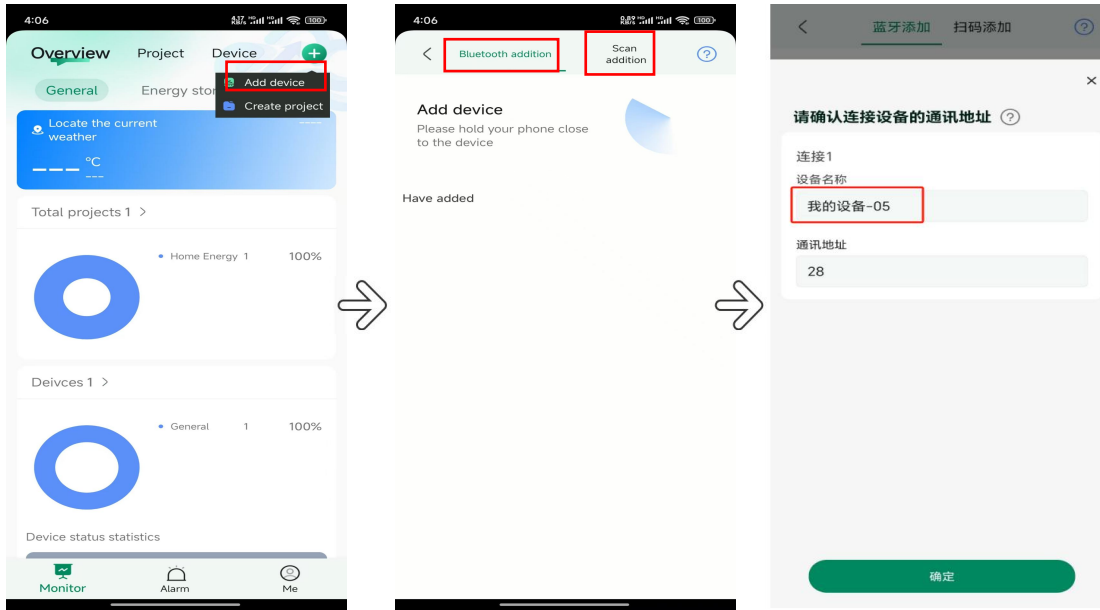

Click the left top corner to add the device → Bluetooth scan the device (or scan the QR code of the data collector to add) → click the device to add → change the device name.

Note: The device name is recommended to be changed to project address or project name.

2.3.2. Add 4G version communication stick

Add 4G version communication equipment, the steps are as follows:

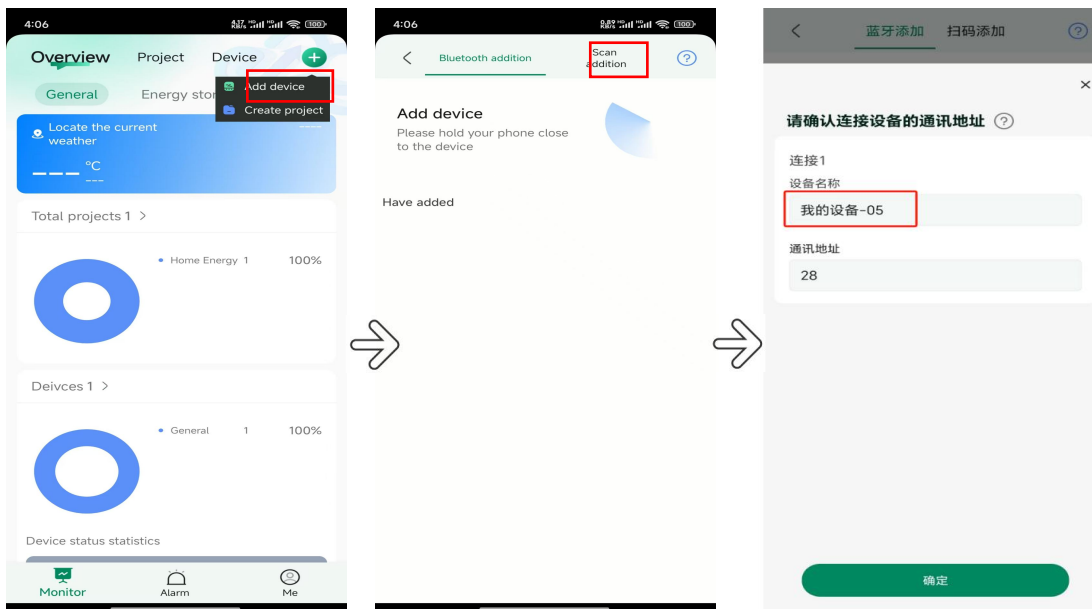

Click the add device in the top left corner → click scan the QR code to add the scanning stick → click add device → change the device name.

Note: The device name is recommended to be changed to project address or project name.

2. 3. 3. Mobile phone APP remote control device

When the device is connected to the network, the device can be controlled through the cloud platform

Operation method: Enter the device page → click the control icon in the upper left corner to enter the control page → select function → send

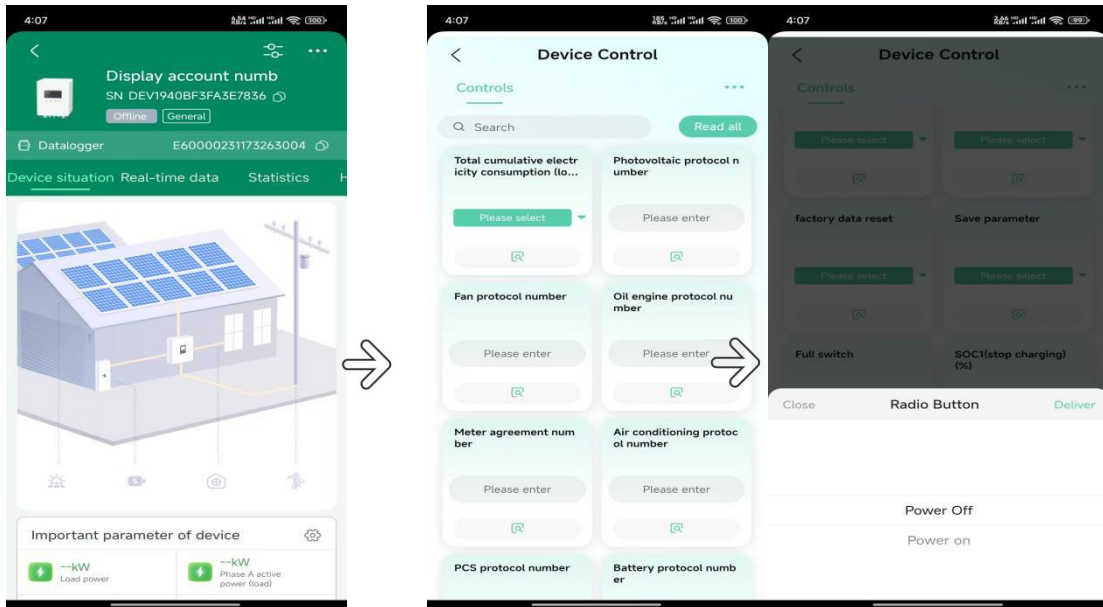

One-click read: Read the current EMS setting value.

EMS mode: Select EMS working mode, you can choose: self-use, photovoltaic Internet access, time function.

PCS protocol number: Select the PCS model.

Battery protocol number: Select the battery protocol number.

Restore factory Settings: Parameters are restored to factory default values (do not set them easily unless necessary)

Save parameters: Save the setting parameters.

All power on/off: Power on or off the device.

SOC (Stop charging): The battery is charged until the SOC (the actual SOC of the battery is greater than or equal to the set value), and the charging will stop when the SOC reaches this value, whether photovoltaic or grid.

SOC2 (off-grid, PV limit point):

SOC3 (off-grid, diesel shutdown): When SOC is greater than or equal to this setting value, EMS controls the diesel generator to shut down.

SOC4 (off-grid, diesel engine starts): When SOC is less than or equal to this setting value, EMS controls the diesel engine starts.

SOC5 (stop charging and shut down the gateway off the grid): not available

SOC6 (machine shutdown): not available

2.3.4. Mobile APP page description

To view system data, you need to log in to the account first, then click on the device, find the device you want to view, and open the device list

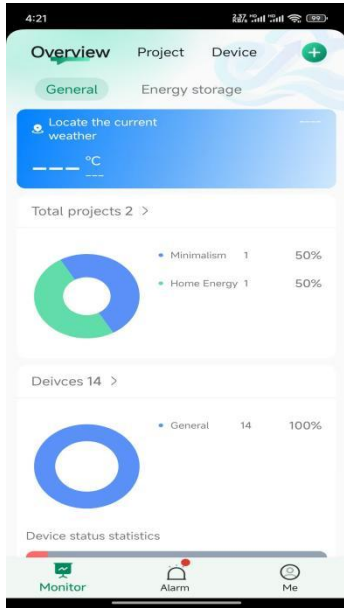

(FIG.) Main interface



(FIG.) Project list interface

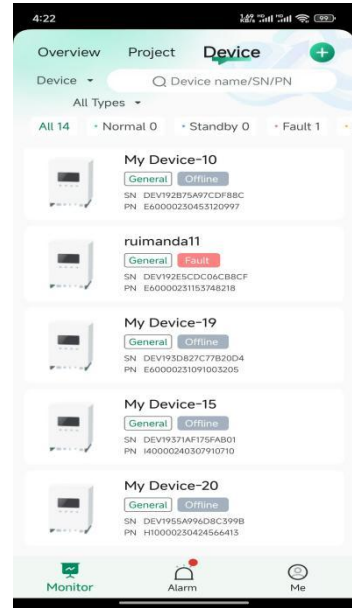

(FIG.) Device parameter interface

Home page: view the account profile, including the number of projects, total number of devices, etc.

Project list interface: Projects are classified according to the project, and a project can be bound to multiple devices.

Device list interface: According to device number, view all accounts bound to the account.

Device interface:

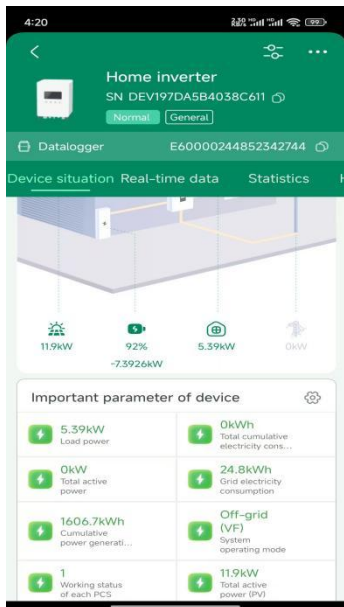

(FIG.) Equipment overview



(FIG.) Real-time parameters

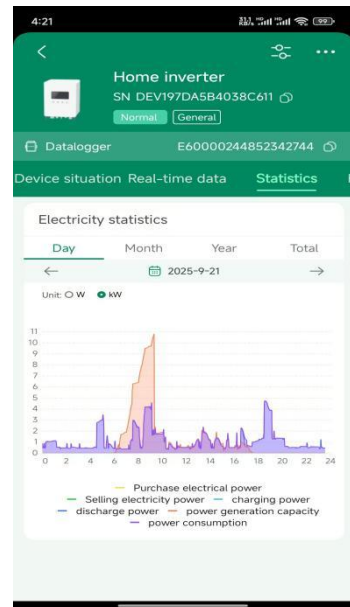

(FIG.) Data statistics

Device overview: View the overview of the device in operation

Real-time parameters: you can view the real-time operating status of the system, PCS

information, BMS information, load and power grid information, system information, diesel generator and wind turbine information.

Data statistics: View power generation and electricity consumption data.

3. PC (web) cloud platform

If the communication stick is a Wifi version, please first configure the Bluetooth network for the communication stick according to Chapter 6.2.2. The web address is: <https://smartems.valueclouds.com>. If you do not have an account, please register an account first.

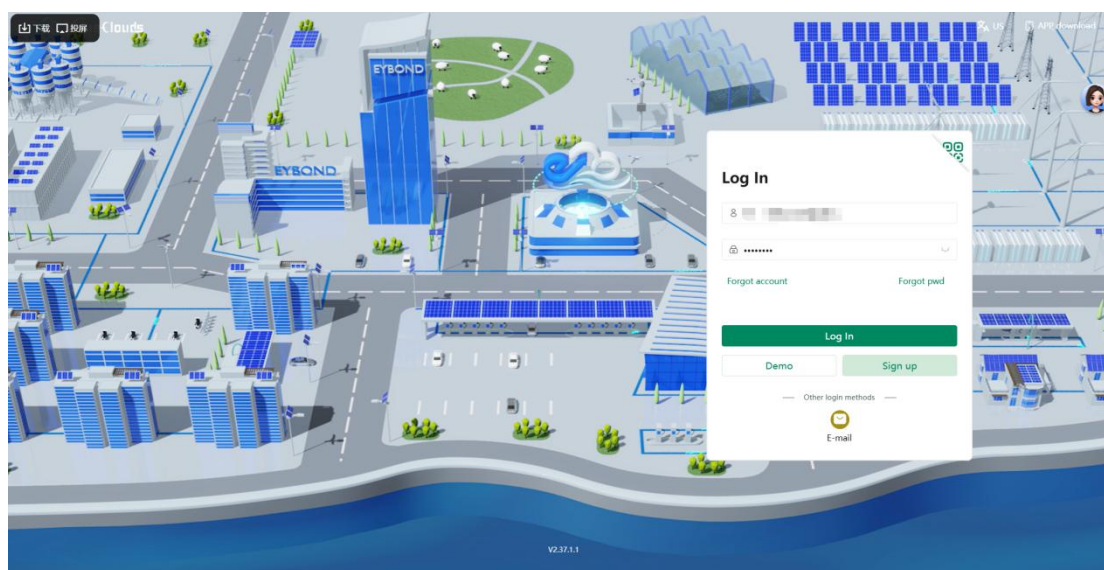

PC login interface (web)

3.1. Add 4G/WiFi communication stick devices to PC (web)

Add 4G/Wifi communication stick device. First, log in to the PC web page. If you have added this device, ignore this chapter.

The steps to add a 4G/Wifi communication stick device are as follows:

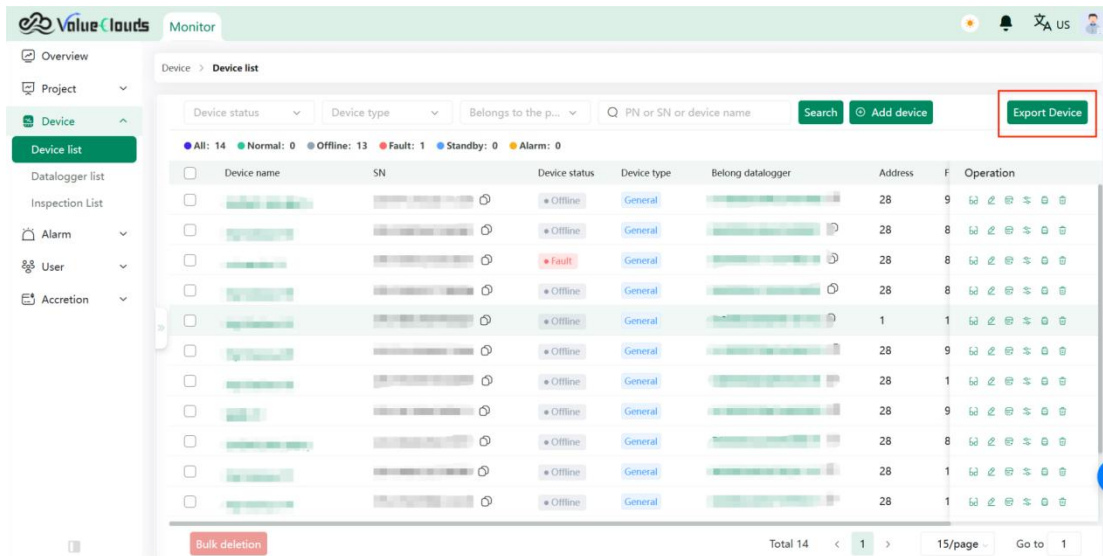

- In the device list, find the add device button in the upper right corner and click the add device button.

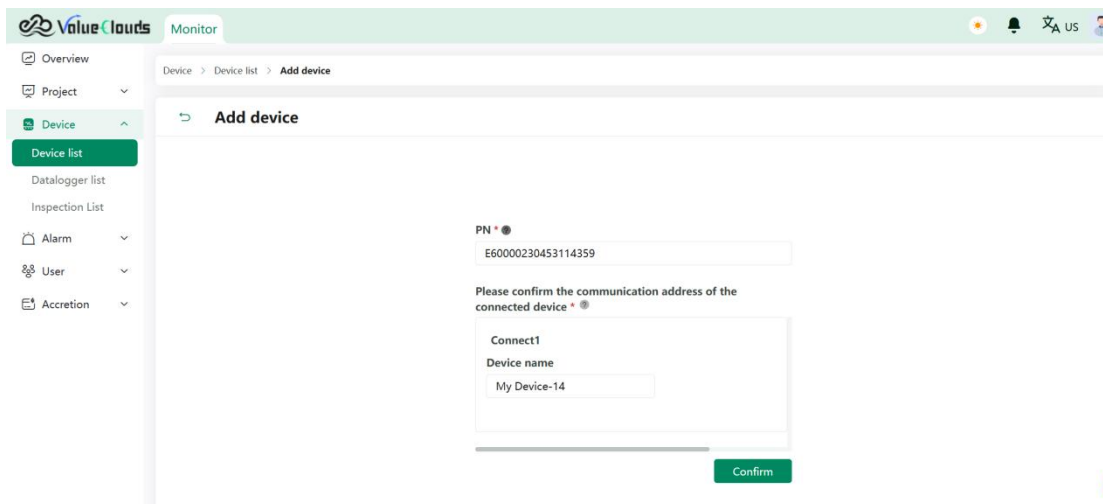

- Fill in the PN number. The PN number is under the QR code of 4G/Wifi communication stick. It is recommended to fill in the device name as the project address, and the device address should not be changed.

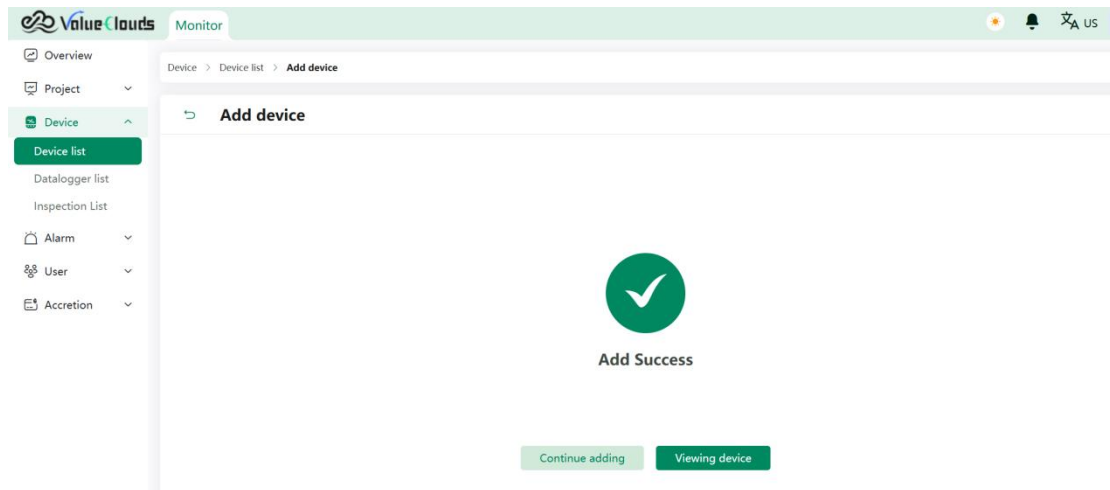

3.2. View system data on the PC (web)

➤ The device that can be clicked to view

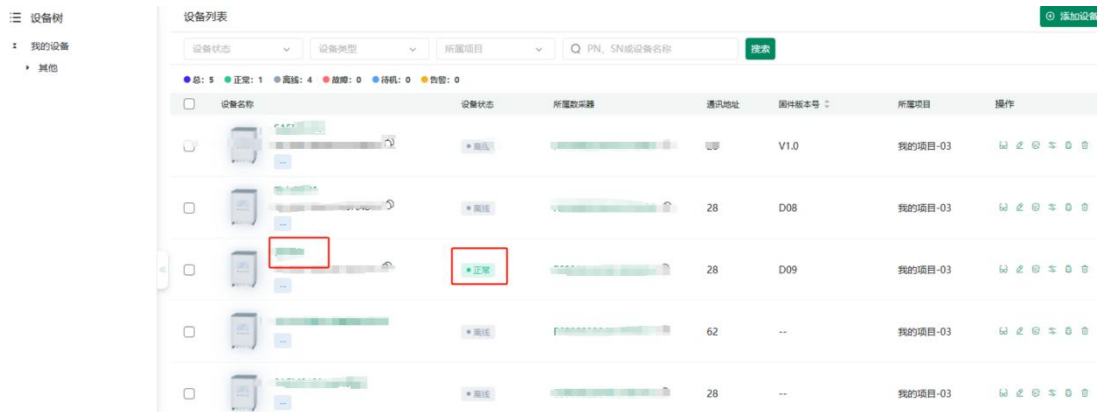

➤ The system information contains the following information



(FIG.) Energy flow chart



(FIG.) System, operating status, load and other information

State	Level	Description	Occurrence time	Disappeared time	Code	Handling suggestion
Abnormal	Warning	The 1# battery BMS is seriously faulty	2025-09-22 14:02:02	2025-09-22 15:10:59	10015	---
Abnormal	Warning	The 1#PCS DC voltage is abnormal	2025-09-22 14:02:02	2025-09-22 15:09:53	10014	---
Abnormal	Warning	The 1# battery BMS is seriously faulty	2025-09-22 14:02:16	2025-09-22 14:41:05	10015	---
Abnormal	Warning	The 1#PCS DC voltage is abnormal	2025-09-22 14:02:16	2025-09-22 14:41:05	10014	---
Abnormal	Warning	The 1# battery BMS alarm is generated	2025-09-22 13:29:59	2025-09-22 14:33:32	10013	---
Abnormal	Warning	The 1# battery BMS alarm is generated	2025-09-22 13:21:41	2025-09-22 13:15:30	10013	---
Abnormal	Warning	The 1# battery BMS alarm is generated	2025-09-18 08:11:05	2025-09-18 09:31:53	10013	---
Abnormal	Warning	The 1# battery BMS is faulty	2025-09-18 08:11:05	2025-09-18 09:31:53	10014	---
Abnormal	Warning	The 1# battery BMS alarm is generated	2025-09-14 08:07:18	2025-09-14 08:58:28	10013	---
Abnormal	Warning	The 1# battery BMS is faulty	2025-09-14 08:07:18	2025-09-14 08:58:28	10014	---
Abnormal	Warning	The 1# battery BMS alarm is generated	2025-07-20 01:17:29	2025-07-20 01:45:17	10013	---
Abnormal	Warning	The 1# battery BMS is faulty	2025-07-20 01:17:29	2025-07-20 01:45:17	10014	---
Abnormal	Warning	The 1# battery BMS alarm is generated	2025-07-19 10:28:29	2025-07-19 10:28:32	10013	---

(FIG.) Equipment alarm

Timestamp	Load power(kW)	Phase A active power	Phase B active power	Phase C active power	Phase A current(A)	Phase B current(A)	Phase C current(A)	Total active power(kW)
2025-09-22 10:41:43	11.49	3.07	4.83	2.68	0.0	0.0	0.0	0.00
2025-09-22 10:36:52	11.24	3.09	4.75	2.59	0.0	0.0	0.0	0.00
2025-09-22 10:31:59	12.06	3.93	4.77	3.25	0.0	0.0	0.0	0.00
2025-09-22 10:27:07	12.01	3.90	4.74	3.37	0.0	0.0	0.0	0.00
2025-09-22 10:22:15	12.36	3.97	4.83	3.57	0.0	0.0	0.0	0.00
2025-09-22 10:17:22	12.33	3.95	4.83	3.56	0.0	0.0	0.0	0.00
2025-09-22 10:11:54	12.04	3.91	4.79	3.34	0.0	0.0	0.0	0.00
2025-09-22 10:06:52	11.93	3.91	4.77	3.20	0.0	0.0	0.0	0.00
2025-09-22 10:01:09	11.93	3.94	4.75	3.34	0.0	0.0	0.0	0.00
2025-09-22 09:56:08	11.74	3.91	4.63	3.29	0.0	0.0	0.0	0.00
2025-09-22 09:51:09	11.79	3.81	4.66	3.31	0.0	0.0	0.0	0.00
2025-09-22 09:46:05	11.77	3.79	4.67	3.31	0.0	0.0	0.0	0.00
2025-09-22 09:41:03	11.85	3.81	4.70	3.30	0.0	0.0	0.0	0.00
2025-09-22 09:36:04	11.85	3.86	4.68	3.31	0.0	0.0	0.0	0.00
2025-09-22 09:31:30	11.71	3.81	4.63	3.27	0.0	0.0	0.0	0.00

(FIG.) Historical data

Click the download icon in the upper right corner of the historical data interface to download the historical data.

III. Wiring instructions

1. EMS interface diagram and definition

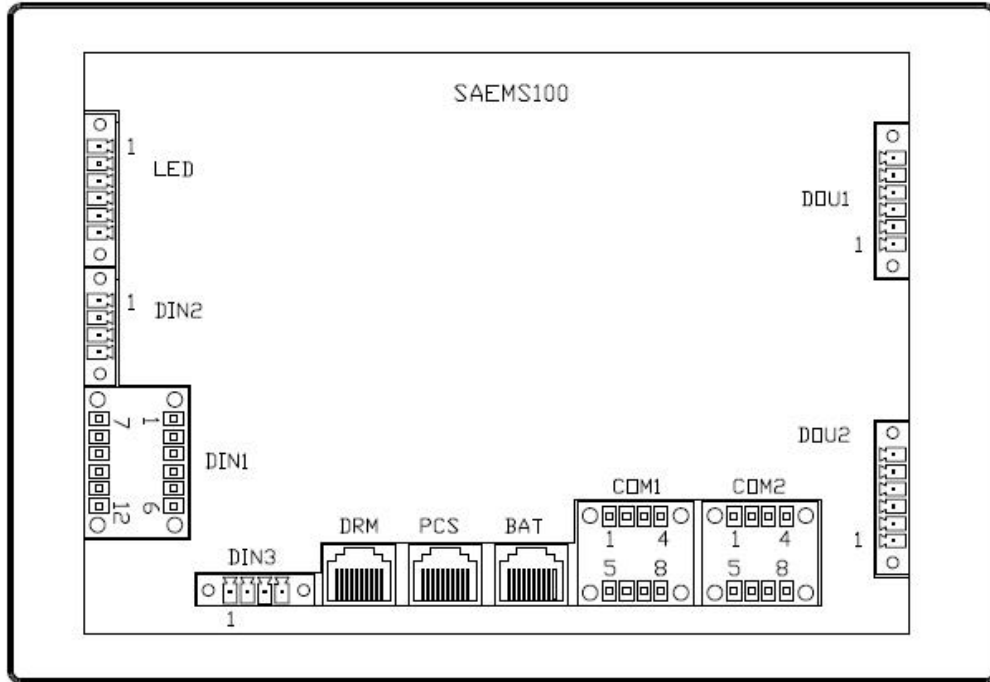

Figure 42 EMS terminal port

Overall interface diagram

characteristic	definition	remarks	
LED	1	LED_12V	12V indicator light power supply
	2	LED_YELLOW_GND	System alarm indicator
	3	LED_12V	12V indicator light power supply
	4	LED_GREEN_GND	System operating indicator light
	5	LED_12V	12V indicator light power supply
	6	LED_RED_GND	System fault indicator
0	1	Vcc supply electricity GND	Important: Please match the appropriate machine 1) AEMS100: Vcc is powered by 5V
	2	Vcc supply electricity GND	
	3	Vcc supply electricity	

	4	Vcc supply electricity	<p>--- adaptation : SP30HBG2</p> <p>2) AEMS200: Vcc is powered by 5V</p> <p>--- adaptation : SP100HC+MPPT</p> <p>3) AEMS300: Vcc---12V power supply</p> <p>--- adaptation : SP60HCG2/SP50HCG2/SP40HCG2/SP30HCG2</p> <p>4) AEMS400: Vcc--12V power supply</p> <p>--- adaptation : SP125HCPS/SP100HCPS</p>	
DRM	RJ45	DRM joggle	See the DRM standard for details	
PCS	RJ45	And power-off or PCS connection cable	Connect to the PCS parallel network port using a Category 5 industrial network cable	
BAT	1	Pin1---BAT_CAN_H	The RJ45 interface mode can also be defined using the 5-8 interfaces in COM1.	
	2	Pin2---BAT_CAN_L		
	7	Pin7---BAT_RTU_A		
	8	Pin8---BAT_RTU_B		
COM1	upper strata	1	DTU/Cloud platform communications	DTU/Cloud platform communications
		2	Wifi/4G_Rtu_485A	
		3	Wifi/4G_Rtu_485B	
		4	Wifi/4G_GND	
	lower level	5	BAT_CAN_H	The same interface as BAT, connected to BMS, CAN or RTU mode can be selected.
		6	BAT_CAN_L	
		7	BAT_RTU_A	
		8	BAT_RTU_B	

	ls			
COM2	upper strata	1	PCS_RTU_A	Communication RTU mode with PCS
		2	PCS_RTU_B	
		3	/	
		4	/	
	lower levels	5	Meter_RTU_A	Meter communication
		6	Meter_RTU_B	
		7	Air_RTU_A	Air-conditioning communication
		8	Air_RTU_B	
DIN1	upper strata	1	DI6	Custom input
		2	COM6	
		3	DI4	Custom input
		4	COM4	
		5	DI2	Custom input
		6	COM2	
	lower levels	7	DI5	Custom input
		8	COM5	
		9	DI3	Custom input
		10	COM3	
		11	DI1	Custom input
		12	COM1	
DIN2	1	EPO	jerk	
	2	EPO-GND		
	3	Power ON/OFF	Power button	
	4	GND		
	5	/		
	6	/		
DOU1	1	DO3	Custom input	
	2	COM3		
	3	DO2	Custom input	
	4	COM2		
	5	DO1	Motor start/stop	
	6	COM1		
DOU2	1	DO6	Custom input	
	2	COM6		
	3	DO5	Custom input	

	4	COM5	Custom input
	5	DO4	
	6	COM4	

2. EMS wiring diagram

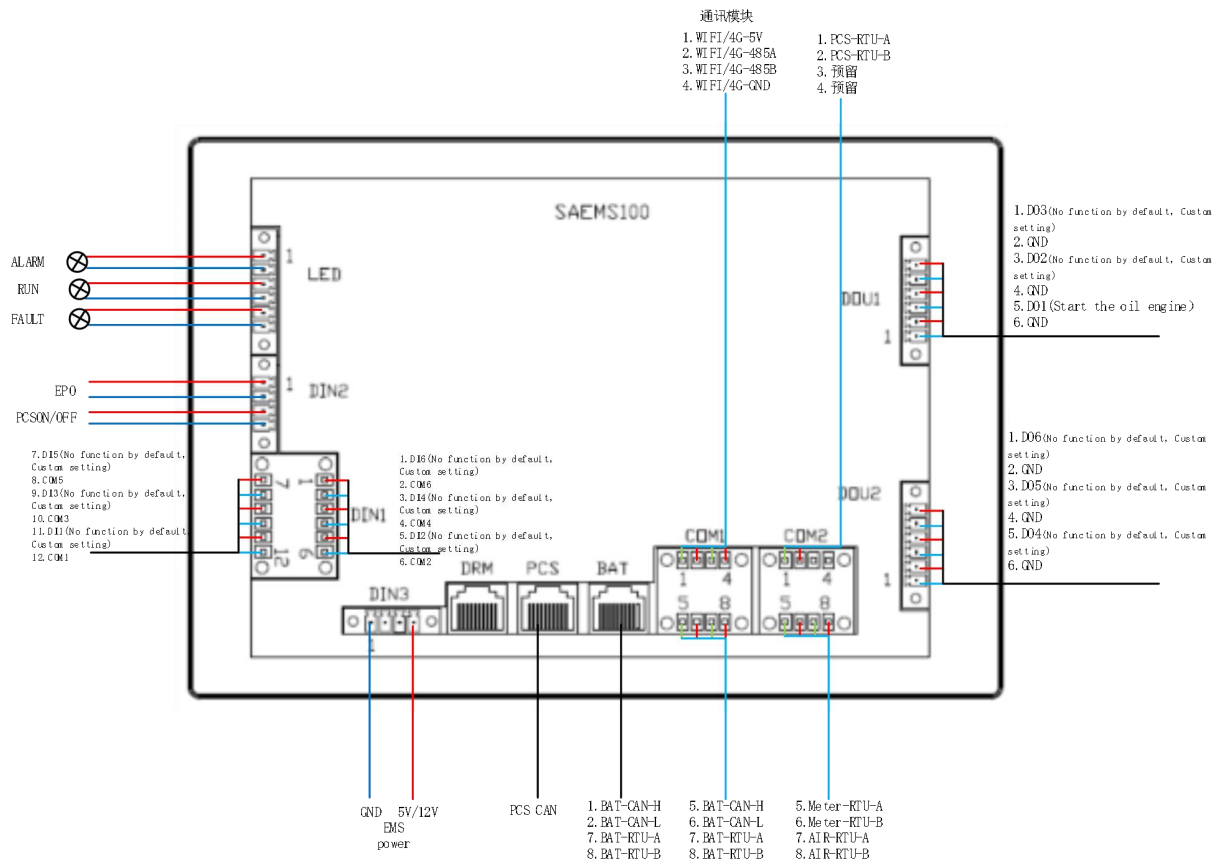

4. Screen program refresh (screen upgrade)

For upgrades, refer to the following steps.

1. Preparations for the burn

Confirm that the TF card is in FAT32 format (if the TF card is not in FAT32 format, please first format the SD card to FAT32). If the TF card is not in FAT32 format, right-click to initialize.

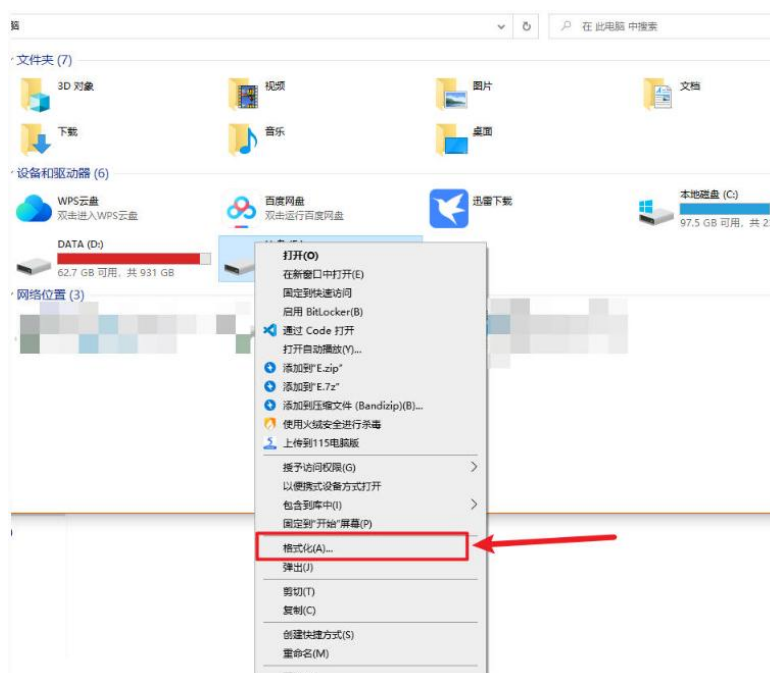

graph 45

Make sure that the size of the SD card is not more than 32G. Before use, make sure that the SD card has no hidden partition (no boot disk), the capacity of the SD card is not more than 32G (for example, 512M,1GB, 2GB, 4GB, 8GB, 16GB, 32GB are available), and the SD card is formatted as fat32 format.

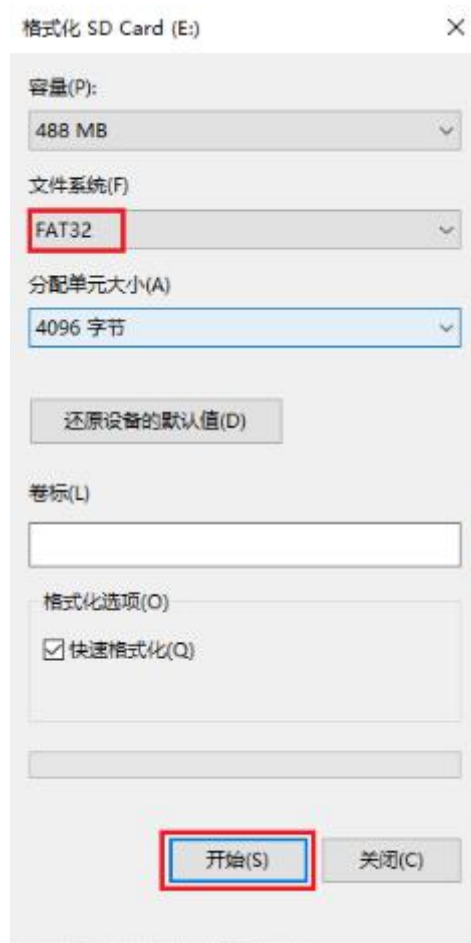

graph 46

Download the project (screen program) to the serial port screen using an SD card. Ensure that the SD card does not exceed 32GB, and copy the TFT file to the root directory of the SD card. There is and can only be one TFT file in the root directory of the SD card, otherwise an error will occur. The following figure shows an example of the file burning.



graph 47

Make sure the read-only attribute in the TFT file properties is unselected.



graph 48

2. Burn screen files

Power off the serial port screen. Insert the TF card into the TF card slot of the serial port screen. The TF card is inserted in the direction where the face with the letter is facing the back of the screen.

Note: Do not plug or unplug the TF card during power on/off of the HMI screen.



graph 49

After inserting the TF card properly, the diagram is as follows.



graph 50

Power on the serial port screen and wait for the program to be burned. The following figure shows the HMI screen burning the program and the program burning.

accomplish .



Figure 51 is burning the file

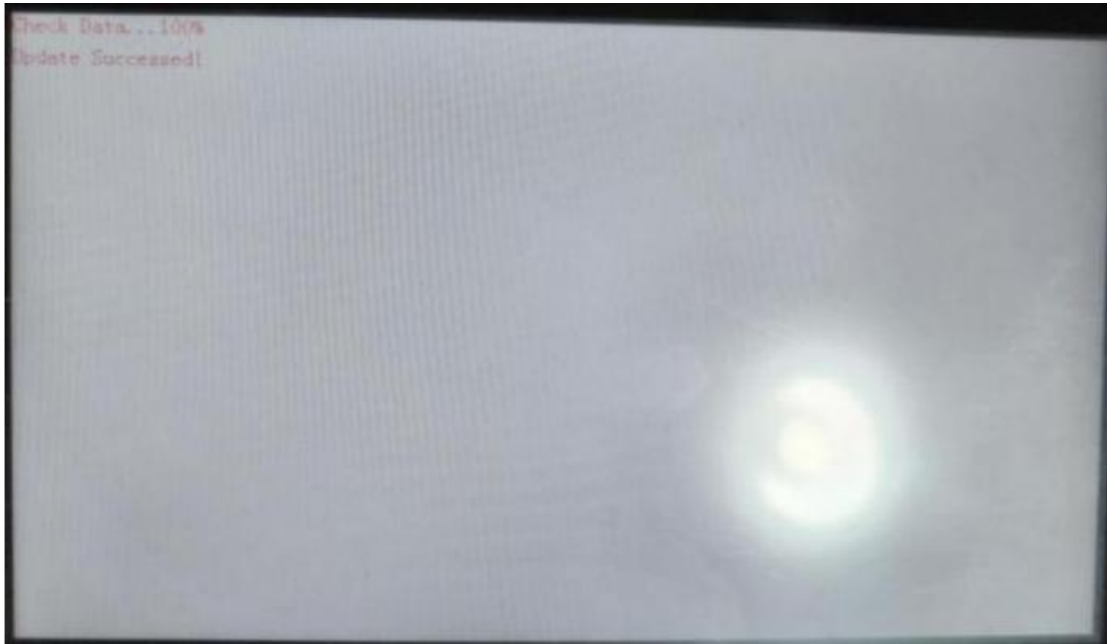
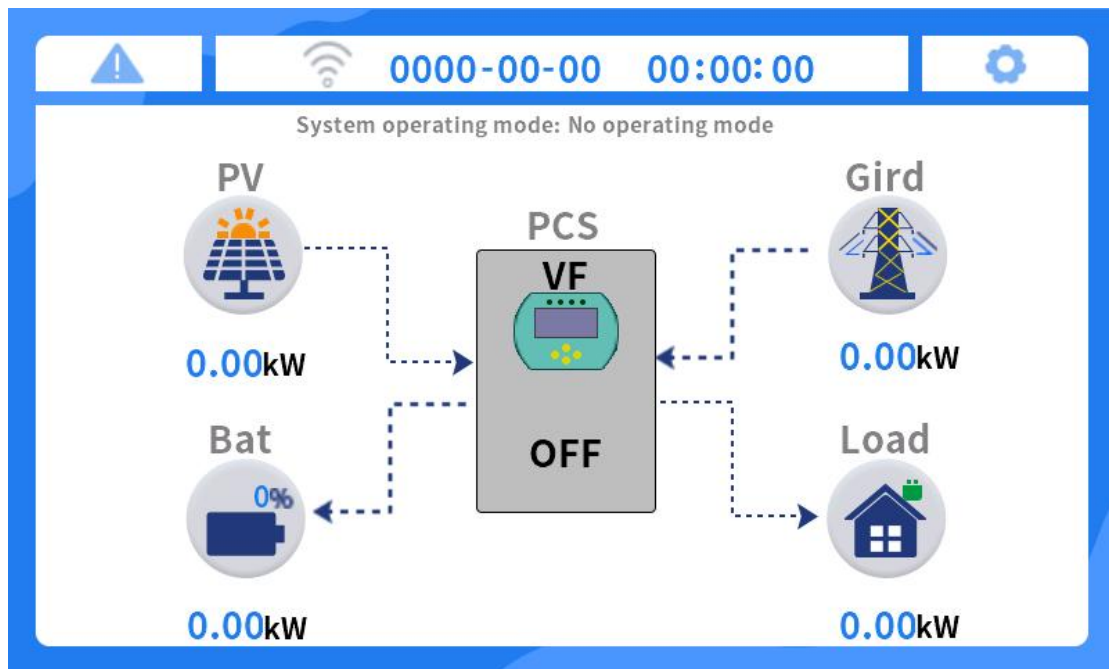

Figure 52 Burn successful

The serial port screen is powered off and the TF card is removed.

The serial port screen is re-powered on and the program is burned in. The picture after burning in is as shown below:



graph 53